

# Stainless steel cylinders Series 92

Single and double-acting (magnetic)  
 ø32 - 40 - 50 - 63 cushioned

- » Clean design
- » Stainless steel AISI 316
- » Adjustable end-stroke cushioning



Stainless steel cylinders Series 92 are suitable for use in the off-shore, naval, pharmaceutical, nuclear and food industries.

This series of cylinders is normally equipped with adjustable end-stroke cushioning. In addition, these cylinders are equipped with a mechanical cushioning in order to make the impact of the piston less noisy as it reaches the end of the stroke. Their construction enables the replacement of all seals.

## GENERAL DATA

<b>Type of construction</b>	end blocks secured to the tube
<b>Operation</b>	single-acting and double-acting
<b>Materials</b>	Stainless steel AISI 316, end blocks, tube, rod NBR seals
<b>Type of mounting</b>	feet - front and rear bracket threaded pin - locking ring for end cap
<b>Stroke</b>	standard (see table)/min.-max. all bores 25-800 mm
<b>Operating temperature</b>	0°C + 80°C (with dry air - 20°C)
<b>Operating pressure</b>	1 ÷ 10 bar
<b>Speed</b>	10 ÷ 1000 mm/sec (no load)
<b>Fluid</b>	clean air, without lubrication If lubricated air is used, it is recommended to use oil ISOVG32. Once applied the lubrication should never be interrupted.

**STANDARD STROKES FOR DOUBLE-ACTING CYLINDERS SERIES 92**

∅	25	50	75	80	100	125	150	160	200	250	300	320	400	500
32	*	*	*	*	*	*	*	*	*	*	*	*	*	*
40	*	*	*	*	*	*	*	*	*	*	*	*	*	*
50	*	*	*	*	*	*	*	*	*	*	*	*	*	*
63	*	*	*	*	*	*	*	*	*	*	*	*	*	*

**CODING EXAMPLE**

<b>92</b>	<b>M</b>	<b>2</b>	<b>A</b>	<b>050</b>	<b>A</b>	<b>0200</b>	
-----------	----------	----------	----------	------------	----------	-------------	--

<b>92</b>	SERIES
<b>M</b>	VERSION M = standard magnetic
<b>2</b>	OPERATION 1 = single-acting (front spring) 2 = double-acting (front and rear cush.) 6 = double-acting (through-rod front and rear cushions)
<b>A</b>	MATERIALS A = stainless steel AISI 316, seals in NBR V = stainless steel AISI 316, all FKM seals
<b>050</b>	BORE (∅): 032 = 32 mm 040 = 40 mm 050 = 50 mm 063 = 63 mm
<b>A</b>	TYPE OF DESIGN A = standard (locking ring for end cap V + lock nut for rod U)
<b>0200</b>	STROKE (see table)
	= standard V = rod seals in FKM

STAINLESS STEEL CYLINDERS SERIES 92

MOVEMENT



Swivel ball joint Mod. GA-90



Piston rod lock nut Mod. U-90



Nose nut V-92



Bracket with threaded pins Mod. T



Foot mount Mod. P



Rod fork end Mod. G-90

All accessories are supplied separately, except for piston rod lock nut Mod. U.



Trunnion bracket Mod. I



Cylinders Series 92



+ = add the stroke

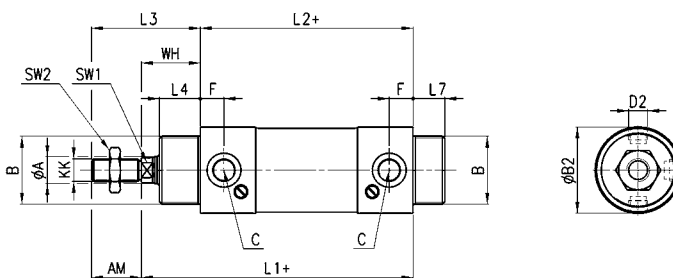

DIMENSIONS

Ø	A	KK	B	B2	C	D2	F	SW1	SW2	AM	WH	L1+	L2+	L3	L4	L7
32	12	M10x1,25	M30x1,5	35	G1/8	M8x1	10.5	10	17	22	26	120	94	48	18	14
40	16	M12x1,25	M38x1,5	44	G1/4	M10x1	15	13	19	24	30	135	105	54	22	16
50	20	M16x1,5	M45x1,5	54	G1/4	M12x1.5	14.5	17	24	32	37	145	106	69	25	18
63	20	M16x1,5	M45x1,5	67	G3/8	M14x1.5	15	17	24	32	37	158	121	69	25	18

Cylinders Series 92

Through-rod.



+ = add the stroke  
++ = add the stroke 2 times

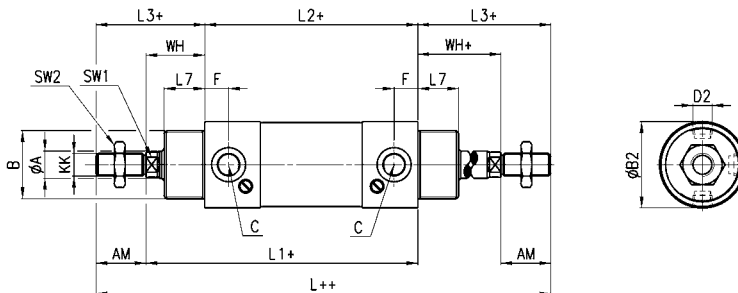

DIMENSIONS

Ø	A	AM	B	F	C	KK	SW1	SW2	WH	L++	L1+	L2+	L3	L4	B2	D2
32	12	22	M30x1,5	10,5	G1/8	M10x1,25	10	17	26	190	120	94	48	18	35	M8x1
40	16	24	M38x1,5	15	G1/4	M12x1,25	13	19	30	213	135	105	54	22	44	M10x1
50	20	32	M45x1,5	14,5	G1/4	M16x1,5	17	24	37	244	143	106	69	25	54	M12x1,5
63	20	32	M45x1,5	15	G3/8	M16x1,5	17	24	37	259	158	121	69	25	67	M14x1,5

**Foot mount Mod. P**

Material: stainless steel 304.  
 Supplied with:  
 1x nut  
 2x single feet

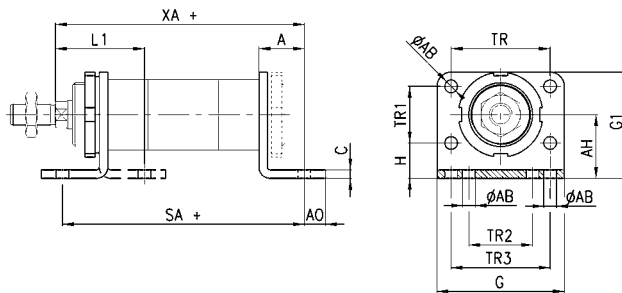

+ = add the stroke

**DIMENSIONS**

Mod.	Ø	A	AB	AO	AH	C	G	G1	TR	TR1	TR2	TR3	H	L1	SA +	XA +
<b>P-92-32</b>	32	24	7	11	32	4	66	53	52	28	32	52	18	46	142	144
<b>P-92-40</b>	40	28	9	15	36	5	80	61	60	30	36	60	21	53	161	163
<b>P-92-50</b>	50	32	9	15	45	6	90	75	70	40	45	70	25	63	170	175
<b>P-92-63</b>	63	32	9	10	50	6	96	85	76	50	50	76	25	63	185	190

**Trunnion bracket Mod. I**

Material: stainless steel 304.  
 Supplied with:  
 1x female trunnion  
 2x pins  
 2x cartridges

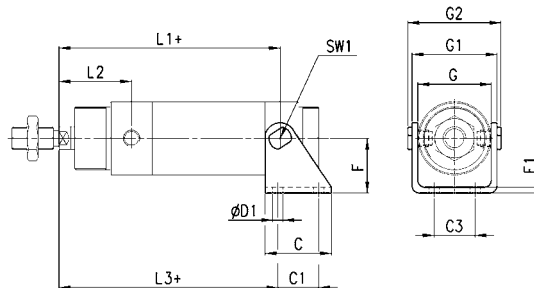

+ = add the stroke

**DIMENSIONS**

Mod.	Ø	C	C1	C2	C3	D1	D2	E1	F	G	G1	G2	L1+	L2	L3+	SW1
<b>I-92-32</b>	32	40	24	46,1	20	7	10	4	35	38,1	50,1	58,1	109,5	36,5	105,5	13
<b>I-92-40</b>	40	50	30	56,1	28	9	12	5	40	46,1	60,1	70,1	120	45	117	17
<b>I-92-50</b>	50	54	34	69,1	36	9	14	6	45	57,1	74,1	86,1	128,5	51,5	124,5	19
<b>I-92-63</b>	63	65	35	82,1	42	9	16	6	50	70,1	88,1	100,1	143	52	142	19

**Bracket with threaded pins Mod. T**

Material: stainless steel 303.  
 Supplied with:  
 2x pins

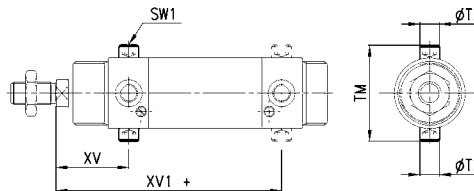

+ = add the stroke

**DIMENSIONS**

Mod.	Ø	XV	XV1 +	TD	TM	SW1
<b>T-42-32</b>	32	36,5	109,5	10	51	5
<b>T-42-40</b>	40	45	120	12	62	6
<b>T-42-50</b>	50	51,5	128,5	14	75	6
<b>T-42-63</b>	63	52	143	16	91	8

Rod fork end Mod. G-90

ISO 8140.  
Material: stainless steel 303.

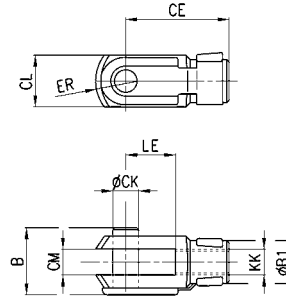

DIMENSIONS										
Mod.	Ø	CK	LE	CM	CL	ER	CE	KK	B	ØB1
<b>G-90-25-32</b>	32	10	20	10	20	12	40	M10x1,25	26	18
<b>G-90-40</b>	40	12	24	12	24	14	48	M12x1,25	32	20
<b>G-90-50-63</b>	50-63	16	32	16	32	19	64	M16x1,5	40	26

Swivel ball joint Mod.GA-90

ISO 8139.  
Material: stainless steel 304.

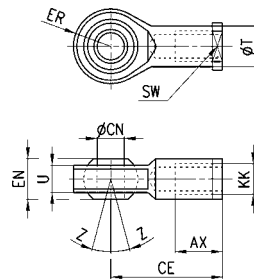

DIMENSIONS											
Mod.	Ø	CN	U	EN	ER	AX	CE	KK	ØT	Z	SW
<b>GA-90-32</b>	32	10	10,5	14	14	20	43	M10x1,25	15	6,5	17
<b>GA-90-40</b>	40	12	12	16	16	22	50	M12x1,25	17,5	6,5	19
<b>GA-90-50-63</b>	50-63	16	15	21	21	28	64	M16x1,5	22	7,5	22

Piston rod lock nut Mod. U-90

UNI 5589.  
Material: stainless steel 304.

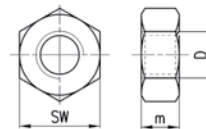

DIMENSIONS				
Mod.	Ø	d	m	SW
<b>U-90-25-32</b>	32	M10x1,25	6	17
<b>U-90-40</b>	40	M12x1,25	7	19
<b>U-90-50-63</b>	50-63	M16x1,5	8	24

Nose nut Mod.V-92

Material: stainless steel 304

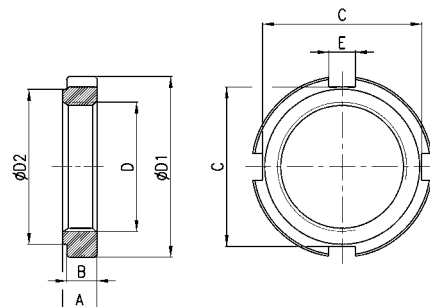

DIMENSIONS								
Mod.	Ø	D	D1	D2	A	B	C	E
<b>V-92-32</b>	32	M30x1,5	42	36	8	7	37	6,2
<b>V-92-40</b>	40	M38x1,5	50	48	10	9	44	7,2
<b>V-92-50-63</b>	50-63	M45x1,5	60	56	10	9	53	7,2