

4GA4/4GB4 SERIES

4GA4/4GB4 SERIES

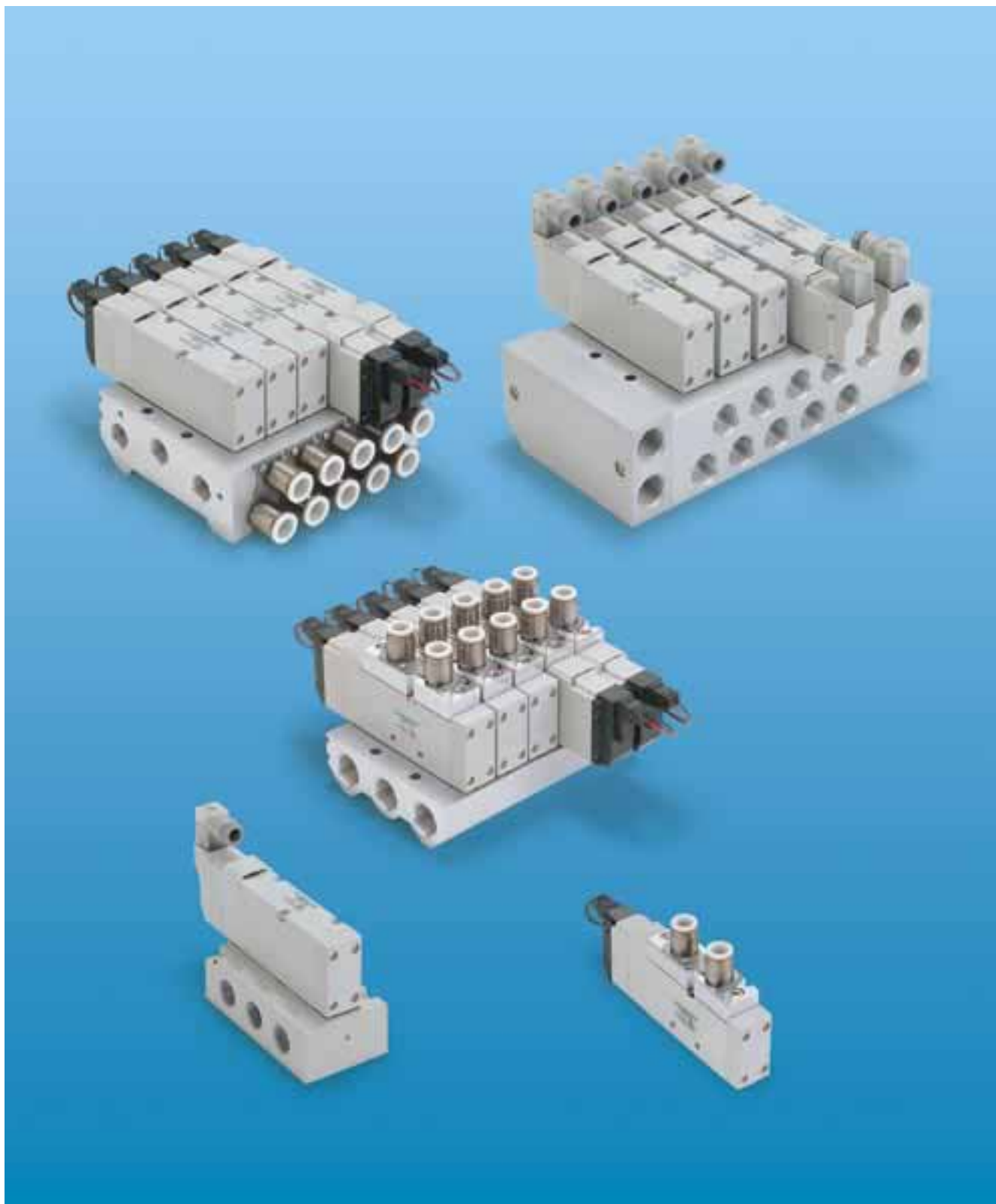

Achieving long life with a large flow rate

The property of the popular 4G1, 2, and 3 Series has been passed on to realize the powerful 4G Series. All factors required by the times, including ecological performance, safety function, and flexibility, have been improved with this large flow rate pneumatic 5-port valve 4G4 Series (metal base type).

Discrete valve, body porting, base porting

4G^A_B4 Series

Maximum C of 15 achieved within a compact body!



Individual wiring manifold

M4G^A_B4 Series

Maximum manifold C of 9.5!



Pneumatic 5-port valve

4G4 Series



Upgraded: Reliability

Long life

Life is now even longer with the improved sliding section and packing, etc.

Filter on air supplying port

This filter prevents the entry of foreign matter and solves problems. This filter is also installable on the A/B port (optional).

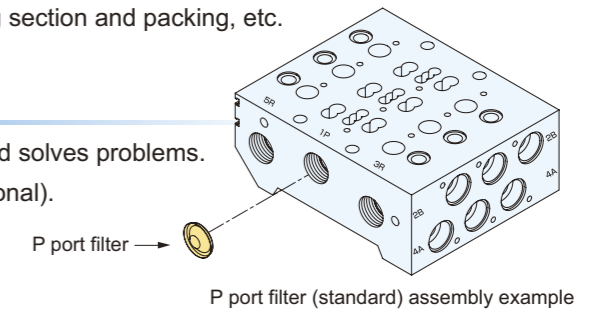

Upgraded: Safety

Reliability increased with the protective cover

Mis-operation of the manual override caused by external force, etc., is prevented. This safe design prevents the cover from being closed when locked. (PAT.)

Upgraded: Operability

Tool-free manual override

This locking/non-locking combination manual override enables finger-tip operation.

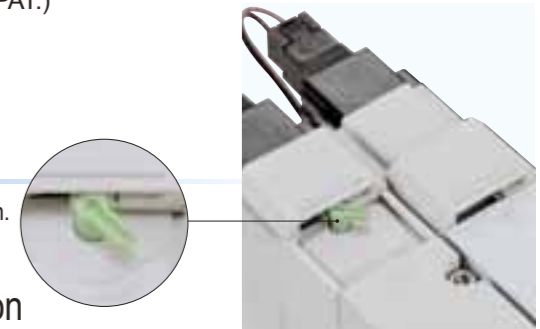

Common wiring connector for top or side installation

Use either top or side installation simply by changing the connector insertion location.

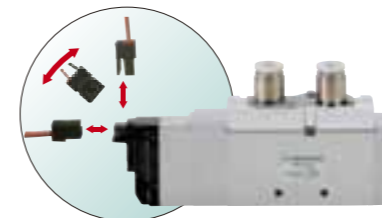

P/R port front lead-out

Front lead-out from the P and R ports is possible by using the supply/exhaust block.

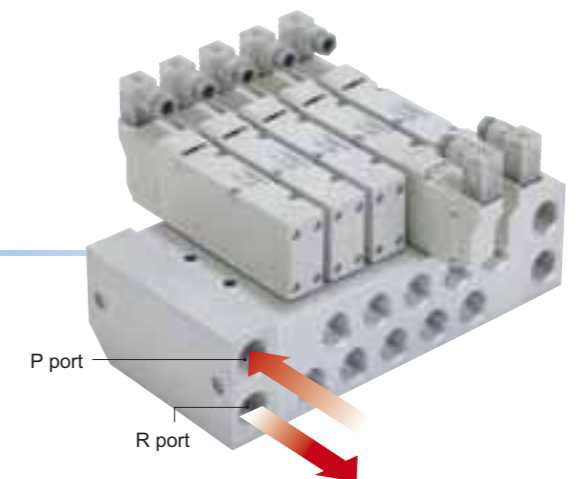

Upgraded: Durability

RoHS Directive compliant

Halogen and vinyl chloride materials have been eliminated from leads. This eco-friendly design complies with RoHS Directives.

RoHS

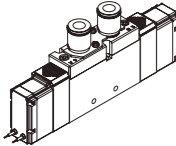
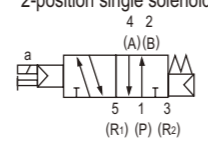
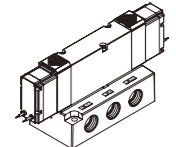
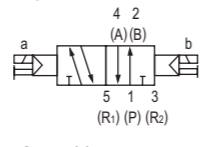
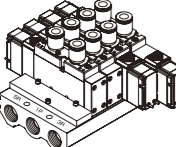
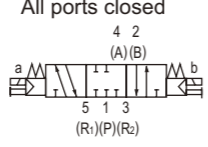
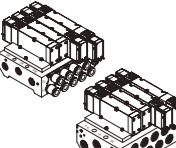
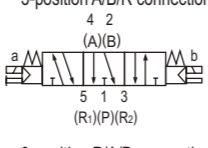
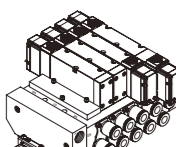
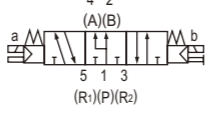
Appearance	Model no.	Position No. of solenoid JIS symbol	Valve performance		Voltage (v)	Solenoid position					A/B piping port									Electric connection				Page			
			Flow characteristics C [dm ³ /(s·bar)]	Applicable cylinder bore size (ø)		2-position		3-position			Push-in joint			Female thread						Grommet lead	E-conector	EJ-conector	DIN terminal box				
						Single solenoid	Double solenoid	All ports closed	ABR connection	PAB connection	Mix	ø8	ø10	ø12	Rc 1/4	Rc 3/8	Rc 1/2	G 1/4	G 3/8						G 1/2	NPT 1/4	NPT 3/8
Note 1																											
Discrete	Body porting		5 port	4GA4	● 5 port valve 2-position single solenoid 	7.5 to 8.6	100 to 140																				1
	Sub-base porting		5 port	4GB4	2-position double solenoid 	12 to 15	125 to 160																				15
Individual wiring type manifold (metal base)	Body porting		Direct mount type	M4GA4	3-position All ports closed 	8.2 to 9.3	100 to 140																				29
	Sub-base porting		Direct mount type	M4GB4 Note 2	3-position A/B/R connection 	6.8 to 7.1 8.7 to 9.5, Note 3	100 to 140																				43
	Sub-base porting		DIN rail Mount type (-D)	M4GB4	3-position P/A/B connection 	6.8 to 7.1	100 to 125																				

Note 1: Effective sectional area S and sonic conductance C are converted as $S \approx 5.0 \times C$.
 Note 2: 2 types of base are available. Dimensions of P/R1/R2 port differ per port size.
 Note 3: The value applies when port size (A/B port) is Rc1/2, G1/2 or NPT1/2.

4GA4/4GB4 Series

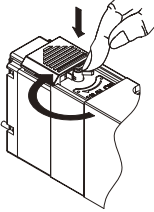
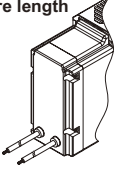
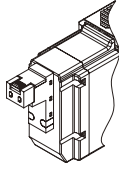
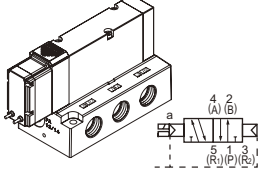
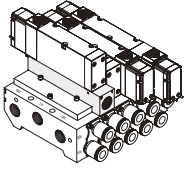
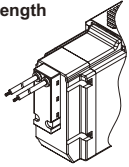
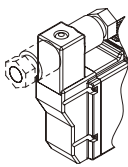
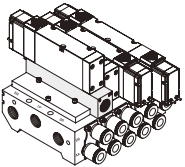
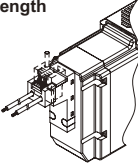
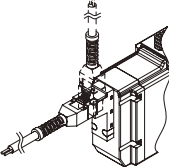
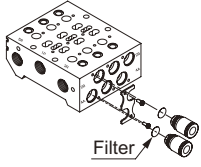
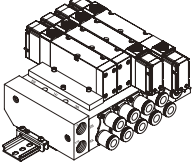
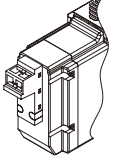
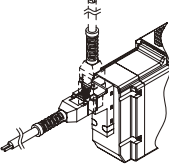
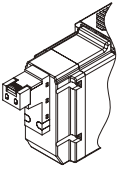
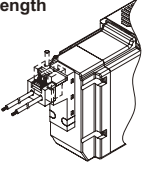
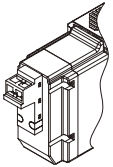
Electric connection		Manual override	Other options	
Discrete valve and individual wiring type manifold				
Blank Grommet lead wire DC specifications (I)	E3 E-connector (K) (L) with socket terminal	<ul style="list-style-type: none"> ● Non-locking Common with locking type (Provided as standard) 	K External pilot	Z1 Air supply spacer
<ul style="list-style-type: none"> ● Lead wire length 300 mm 				
Blank Grommet lead wire AC specifications (I)	B DIN terminal box	<ul style="list-style-type: none"> ① As non-locking ON when pushed OFF when released ② As locking ON state is held by PUSH + 90 ° clockwise rotation Turn counterclockwise to release lock OFF 	A Coolant proof	Z3 Exhaust spacer
<ul style="list-style-type: none"> ● Lead wire length 300 mm 			Select for measures against entry of coolant or against ozone.	
E0 E-connector (I)	E0*J EJ-connector (I)		F AB port filter Integrated	D DIN rail mount
<ul style="list-style-type: none"> ● Lead wire length 300 mm 500 mm 1000 mm 2000 mm 3000 mm 				
E0N E-connector Without socket	E2*J EJ-connector (I) (K) (L)			
				
E1 E-connector With socket terminal				
				
E2 E-connector (I) (K) (L)				
<ul style="list-style-type: none"> ● Lead wire length 300 mm 500 mm 1000 mm 2000 mm 3000 mm 				
E2N E-connector Without socket (K) (L)				
				

Electric connection circuit diagram

Electric connection (wiring method) (None): No lead wire (I): With lead wire (L): With indicator light
(K): With surge suppressor (S): Without socket

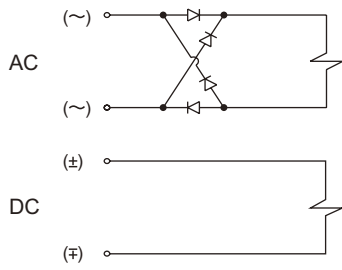
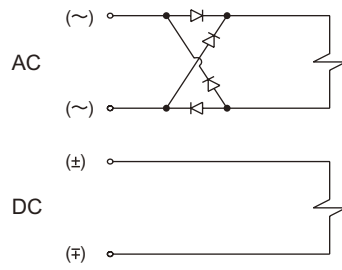
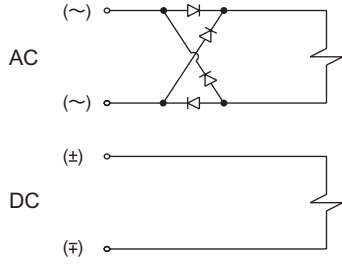
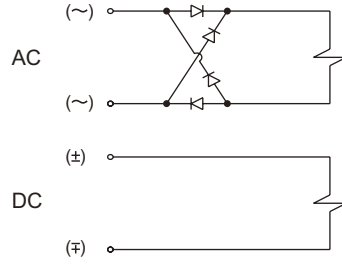
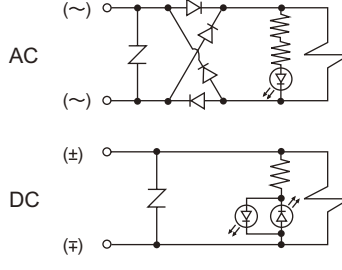
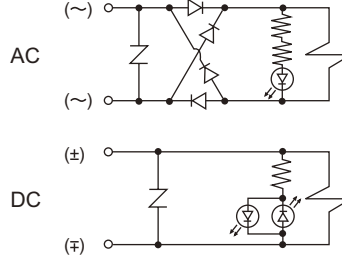
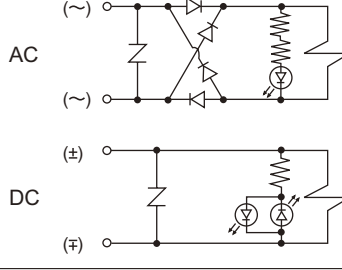
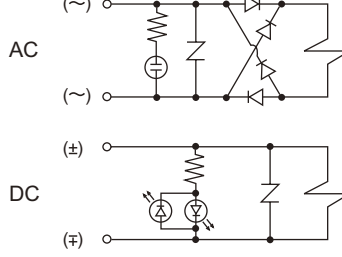
Blank	Grommet lead wire (I)	E0 E0*J	E-connector, EJ-connector (I)
			
E0N	E-connector (S)	E1	E-connector (None)
			
E2 E2*J	E-connector, EJ-connector (I) (L) (K)	E2N	E-connector (L) (K) (S)
			
E3	E-connector (None) (L) (K)	*Zener diode is used for a surge suppressor.	
			
B	DIN terminal box (I) (L) (K)		
			



Safety precautions

Always read this section before starting use.

When designing and manufacturing a device using CKD products, the manufacturer is obligated to check that device safety mechanical mechanism, pneumatic control circuit, or water control circuit and the system operated by electrical control that controls the devices is secured.

It is important to select, use, handle, and maintain the product appropriately to ensure that the CKD product is used safely.

Observe warnings and precautions to ensure device safety.

Check that device safety is ensured, and manufacture a safe device.

WARNING

1 This product is designed and manufactured as a general industrial machine part. It must be handled by an operator having sufficient knowledge and experience in handling.

2 Use this product in accordance of specifications.

This product must be used within its stated specifications. It must not be modified or machined.

This product is intended for use as a general-purpose industrial device or part. It is not intended for use outdoors or for use under the following conditions or environment.

(Note that this product can be used when CKD is consulted prior to use and the customer consents to CKD product specifications. The customer must provide safety measures to avoid risks in the event of problems.)

- ① Use for special applications requiring safety including nuclear energy, railroad, aviation, ship, vehicle, medical equipment, equipment, or applications coming into contact with beverage or food, amusement equipment, emergency shutoff circuits, press machine, brake circuits, or for safeguard.
- ② Use for applications where life or assets could be adversely affected, and special safety measures are required.

3 Observe corporate standards and regulations, etc., related to the safety of device design and control, etc. ISO4414, JIS B8370 (pneumatic system rules)

JFPS2008 (principles for pneumatic cylinder selection and use)



Including High Pressure Gas Maintenance Law, Occupational Safety and Sanitation Laws, other safety rules, body standards and regulations, etc.

4 Do not handle, pipe, or remove devices before confirming safety.

- ① Inspect and service the machine and devices after confirming safety of the entire system related to this product.
- ② Note that there may be hot or charged sections even after operation is stopped.
- ③ When inspecting or servicing the device, turn off the energy source (air supply or water supply), and turn off power to the facility. Discharge any compressed air from the system, and pay enough attention to possible water leakage and leakage of electricity.
- ④ When starting or restarting a machine or device that incorporates pneumatic components, make sure that the system safety, such as pop-out prevention measures, is secured.

5 Observe warnings and cautions on the pages below to prevent accidents.

■ The safety cautions are ranked as “DANGER”, “WARNING” and “CAUTION” in this section.

-  **DANGER:** When a dangerous situation may occur if handling is mistaken leading to fatal or serious injuries, or when there is a high degree of emergency to a warning.
-  **WARNING:** When a dangerous situation may occur if handling is mistaken leading to fatal or serious injuries.
-  **CAUTION:** When a dangerous situation may occur if handling is mistaken leading to minor injuries or physical damage.

Note that some items described as “CAUTION” may lead to serious results depending on the situation. In any case, important information that must be observed is explained.

Disclaimer

1. CKD cannot be held liable for any business interruption, loss of profit, personal injury, delay cost, or any other ancillary or indirect loss, cost, or damage resulting from the use of or faults in the use of CKD products.
2. CKD cannot be held responsible for the following damage:
 - ① Damage resulting from failure of CKD parts due to fire from reasons not attributable to CKD, or by intentional or negligence of a third party or customer.
 - ② When a CKD product is assembled into customer equipment, damage that could have been avoided if customer equipment were provided with functions and structure, etc., generally accepted in the industry.
 - ③ Damage resulting from use exceeding the scope of specifications provided in CKD catalogs or instruction manuals, etc., or from actions not following precautions for installation, adjustment, or maintenance, etc.
 - ④ Damage resulting from production modifications not approved by CKD, or from faults due to combination with other software or other connected devices.



Pneumatic components

Safety precautions

Always read this section before starting use.

Refer to Pneumatic valves Catalog No. CB-023SA for the general valves.

Design & Selection

1. Common

WARNING

- Use this product in accordance with the specifications range.

Products in this catalog are for use only in a compressed air system. Use with pressure or temperature exceeding the specification range may result in damage or operation faults. (Refer to the specifications.)

Consult with CKD when using fluids other than compressed air.

- When using the 3-position valve all port block as a brake, operation does not stop at the precise position because of air compression.

When using for pressure holding applications, devices such as the valve and cylinder tolerate air leakage, so the brake position may change or pressure may drop.

- Do not block exhaust port of a manifold valve.

- Other cylinders could malfunction due to back pressure generated by switch valve exhaust. Exhaust from both sides of the manifold or use a discrete exhaust valve with a spacer or discrete valve for the valve.

CAUTION

- Check leakage current to prevent malfunction caused by leakage current from other fluid control components.

- When using a programmable controller, etc., the solenoid valve could malfunction because of leakage current. The value affected by leakage current differs with the solenoid valve.

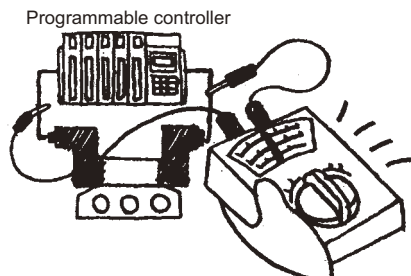

For 100 VAC	3.0mA or less
For 12 VDC	1.5mA or less
For 24 VDC	1.8mA or less

- Use dry compressed air that does not cause condensation in piping.

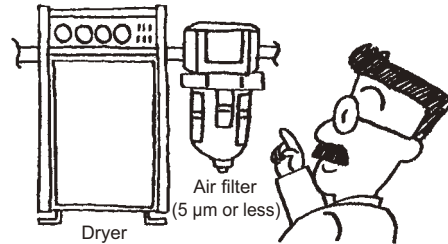

- If the temperature drops in pneumatic piping or pneumatic devices, drainage could form.
- If the drainage enters the air passage of the pneumatic device, it could cause the passage to instantly block, resulting in operation faults.
- Drainage could cause rust, making the pneumatic device fail.
- Drainage may also wash out lubricant and cause lubrication faults.

2. Surge suppressor

CAUTION

- The surge suppressor enclosed with the solenoid valve is to protect the output contact for that solenoid valve's drive. There is no significant protection for other devices in the area, and the surge may cause damage or malfunctions. Surge generated by other devices could be absorbed and cause damage such as burning. Care must be taken for points below.

- The surge suppressor limits solenoid valve surge voltage, which can reach several hundred volts, to a lower voltage level withstandable by the output contact. Depending on the output circuit used, this may be insufficient and could result in damage or malfunction. Check whether the surge suppressor can be used by the surge voltage limit of the solenoid valve in use, the output device's withstand pressure and circuit structure, and by the degree of return delay time. If necessary, provide other surge measures. The 4G Series solenoid valve surge suppressor suppresses reverse voltage surge generated at OFF as shown in the following table.

Rated voltage	Reverse voltage value when power turned OFF
12 VDC	Approx. 27V
24 VDC	Approx. 47V

Design & Selection

- When using the NPN output unit, a surge voltage equivalent to the voltage above plus the power voltage surge could be applied. Provide contact protection circuit.

<Output transistor protection circuit parallel setting example 1>

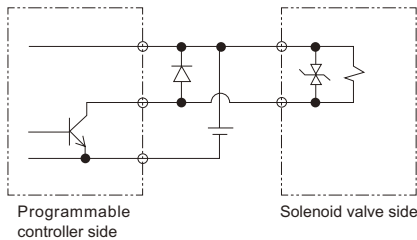

<Output transistor protection circuit parallel setting example 2>

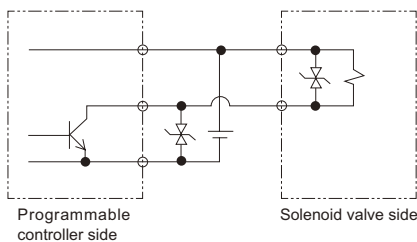

- If another device or solenoid valve is connected in parallel to the solenoid valve, reverse voltage surge generated when the solenoid valve is off is applied to these devices. Even when using the solenoid valve with a 24 VDC surge suppressor, the surge voltage could reach several tens of volts depending on the model. This reverse polarity voltage could damage devices connected in parallel or cause them to malfunction. Avoid parallel connection of devices suspected of reversing polarity voltages, e.g., LED indicators. When driving several solenoid valves in parallel, the surge from other solenoid valves could enter the surge suppressor of one solenoid valve with a surge suppressor. Depending on the current value, that surge suppressor could burn. When driving several solenoid valves with surge suppressors in parallel, surge current could concentrate at the surge suppressor with the lowest limit voltage and cause similar burning. Even if the solenoid valve type is the same, the surge suppressor's limit voltage can be inconsistent, and in the worst case, could result in burning. Avoid driving several solenoid valves in parallel.

- The surge suppressor incorporated in the solenoid valve often short-circuits if damaged by overvoltage or overcurrent from a source other than the solenoid valve. If the surge suppressor fails, if a large current flows when output is on, the output circuit or solenoid valve could be damaged or ignite. Do not keep power on in a faulty state. Provide an overcurrent protection circuit on the power or drive circuit or use a power supply with overcurrent protection so that a large current does not flow continuously.

3. AC specifications

⚠ CAUTION

- AC specifications have a built-in all-wave-rectified circuit.

When using an SSR to turn the solenoid valve on and off, a solenoid valve reset fault may occur depending on the SSR.

Take care when selecting the SSR. (Consult with the relay or PLC manufacturer.)

Installation & Adjustment

1. Common

⚠ WARNING

- If the solenoid valve's manual override is activated, return to the origin (initial point) before starting the device.

For non-locking type, confirm automatic reset. For locking type, confirm that the lock is released (OFF).

(Example)

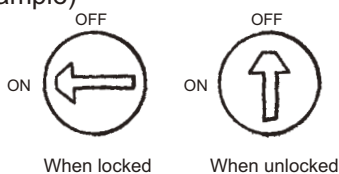

- The solenoid valve functions simultaneously with power turn-on causing a hazardous state.
- If operated at the actuation location with the manual override, abnormal operation could occur.

⚠ CAUTION

■ Port indication

Port positions such as 1P and 4A, etc., are indicated in accordance with ISO and JIS standards.

Applications	ISO standards	JIS standards
Supply port	1	P
Output port	4	A
Output port	2	B
Exhaust port	5	R1
Exhaust port	3	R2
Pilot air supplying port	12/14	PA
Pilot exhaust port	82/84	PR

- Any valve mounting attitude is permissible. Check the port symbol to pipe as a reverse action such as cylinder, etc., is not created.

■ Apply adequate torque when connecting pipes.

To prevent air leak and to protect thread. Tighten by hand at first, then use the tool, so as screw thread is not damaged.



(Reference value)

Port thread	Tightening torque N·m
Rc 1/8	3 to 5
Rc 1/4	6 to 8
Rc 3/8	13 to 15
Rc 1/2	16 to 18

2. External pilot (K) piping port

⚠ CAUTION

■ Metal base 4G^A_B4 Series

- The external pilot (K) type has individual exhaust specifications for pilot air exhaust. Rc1/8 ports are used for both pilot air intake and exhaust ports. Check that piping connection is correct. Incorrect piping causes operation faults.

Port indication

Applications	Indication (ISO standards)	
Pilot air	Air supplying port	12/14
	Exhaust port	82/84

Base piping-discrete valve 4GB4

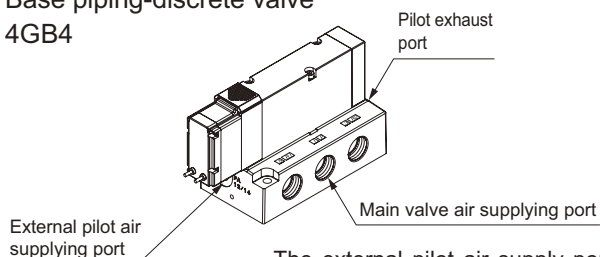

The external pilot air supply port is on the left side facing the main valve air supply port.

Manifold M4G^A_B4

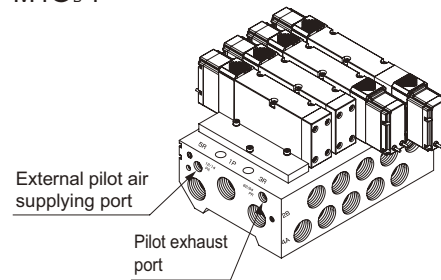

The external pilot supply is on the top of the manifold. There are two locations on either side.

M4G^A_B4 Supply and exhaust block (Q)

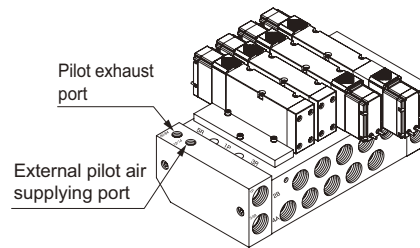

The external pilot supply is on the far side from the A/B ports. There are two locations on either side.

3. How to install discrete body porting (A)

⚠ CAUTION

■ For direct installation

- The 4GA4 Series with discrete body porting is installed from the through hole.

4GA4 Series 2 through holes

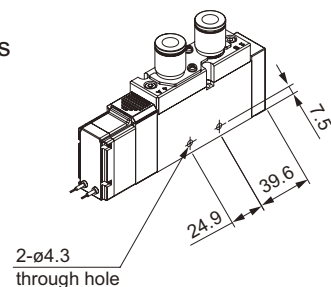

4. How to install manifold (Metal base 4G^A_B4 Series)

⚠ CAUTION

■ For direct installation

- The M4G^A_B4 Series is installed by tightening through bolts on the top of the manifold base.

How to install M4G^A_B4 Series

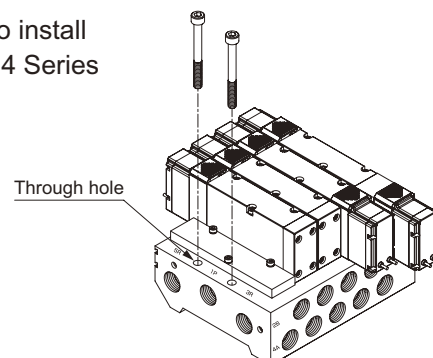

Installation & Adjustment

■ Installation with DIN rail

- The DIN rail model has stands on the supply and exhaust block at both ends to suppress vibration and impact. Ensure a flat surface with the range (width 57 + 36 mm) below so that the stand is seated against the DIN rail installation.

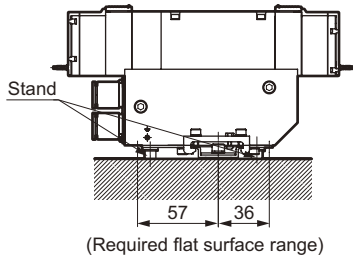

Fix the DIN rail at a spacing of 75 to 100 mm using M5 bolts and enclosed square washers. Check that installation has no problems before starting use. Install the valve where the retainer or supply and exhaust block will not interfere with M5 bolts. A steel DIN rail is used to ensure strength. When preparing a DIN rail separately, use a steel DIN rail.

Retainer tightening torque: 2.5 to 3.0 N·m

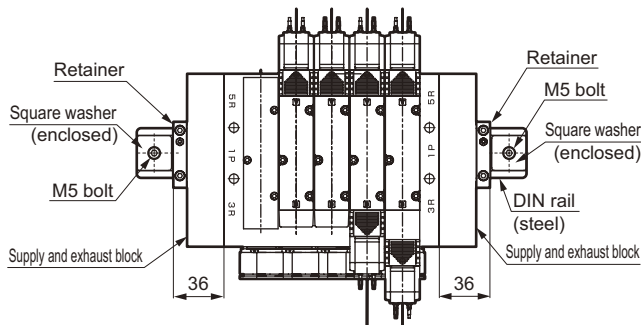

If the DIN is not installed correctly, the manifold could drop off or be damaged. Up to five stations can be installed in a rail.

5. Lead wire wiring

⚠ CAUTION

- Lead standards differ with the type of wire connection. Connect wires appropriately.

Leads used with the 4GA4 Series are shown below.

Electric connection	Descriptions	Conductor size	Cross-section areas	Isolator O. D.	Sheath O. D.
Blank	Grommet lead wire	AWG#20	0.5 or equivalent	1.76	-
E*	E-connector (with lead wire)	AWG#26	0.13 or equivalent	1.35	-
E*J	EJ-connector	AWG#25	0.2 or equivalent	1.14	3.7

When installing a manifold and connecting wires, check that leads do not apply tension to the solenoid valve coil.

6. How to use E-connector

⚠ CAUTION

- The E-connector is a top/side connector to which sockets can be connected to either the top or side ways. The socket assembly is enclosed with the valve. Select the connection direction based on installation.

■ How to mount or dismount socket

- When installing the socket, hold the lever and socket with your fingers and insert straight into the square window on the connector. Align the lever with the groove on the connector and lock. When installing from the top, face the socket so that the lever is in front. When installing from the side, face the socket so that the lever is on the top.
- When pulling the socket out, press down on the lever to release jaws from the groove, then pull straight out.

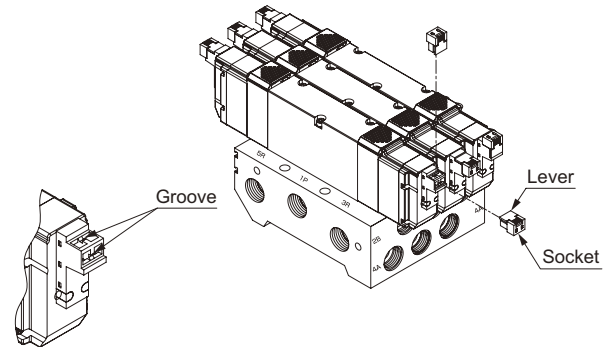

■ How to connect lead wire

- Peel away about 3 cm of the lead sheath, arrange the ends of core wires, and insert them into the contact terminal. Crimp with a crimping tool. Crimp both the sheath and wire, and check that 0 to 0.5 mm of the core wire is visible.
- After crimping, turn the contact terminal as shown below, and insert into the square window on the socket. The terminal locks when it is inserted into the back. After insertion, tug lightly on the terminal to check that it is locked.

Caulking tool (MITSUMI H4-M31)

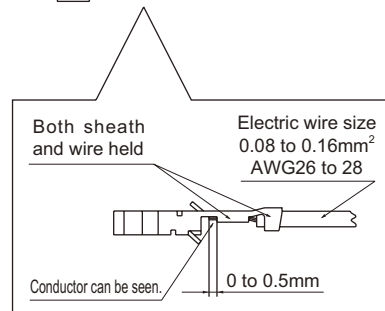
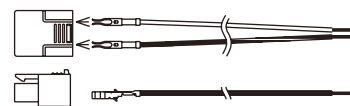

7. How to use E*J-connector

⚠ CAUTION

■ Dimensions below apply as the lead bending limit.

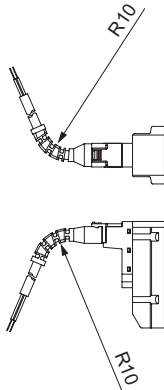

8. DIN terminal box

⚠ WARNING

■ Turn power off before disassembling or assembling the terminal box because of the risk of electrical shock.

⚠ CAUTION

■ Disassembling

- Loosen screw ①, and pull cover ② in the direction of screw ①. The connector will come off of coil assembly ⑫.
- Pull screw ① out of cover ②.
- Notch ⑨ is on the bottom of terminal block ③ (next to the GDSN mark). Insert a small flat-tip screwdriver between housing ② and terminal block ③, and twist it. Terminal block ③ will come off cover ②. (Refer to Fig. 1.) Remove the gland while not applying an excessive force. Failure to observe this, the product could be damaged.
- Remove cable gland ④, and remove washer ⑤ and rubber packing ⑥.

Drawing 1

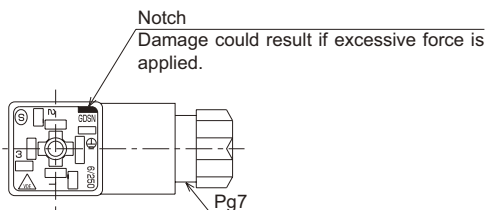

Deal drawing

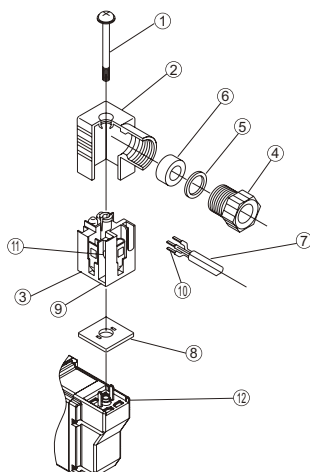

■ Wiring

- Wiring preparation
 - The cable ⑦ applicable outline dimensions are VCTF2 (3) core (3.5 to 7 in diameter) specified in JISC3306.
 - Peel back 10 mm of the cable lead sheath.
 - Either twisted wires or single conductors are connected.
 - When using twisted wires, avoid connecting soldered wires.
 - When using crimping sleeve ⑩ on the end of twisted wire, use Nihon Weidmüller H0.5/6 (0.3 to 0.5 mm²), H0.75/6 (0.75mm²), or an equivalent. The crimping sleeve must be prepared by the user.
- Wiring
 - Pass cable gland ④, washer ⑤, and rubber packing ⑥ in this order through cable ⑦, and insert into cover ②.
 - Connect to terminal 1 and 2. There is no polarity.
 - Recommended tightening torque is 0.2 to 0.25N·m.

■ Assembly

- Set connected terminal block ③ onto cover ②. (Press in until it clicks.)
 - * The terminal block can be set in four directions (Fig. 2).
- Set rubber packaging ⑥ and washer ⑤ in this order into cover ② cable lead-in port, then securely tighten cable gland ④.
 - Remarks: Reference tightening torque of cable gland is 1.0 to 1.5N·m.
 - Check that the cable cannot be pulled out.
- Set gasket ⑧ between the bottom of terminal block ③ and coil assembly ⑫ plug, and insert the connector. Insert screw ② from the top of cover ① and tighten.
 - Remarks: Recommended tightening torque of set screw is 0.2 to 0.25N·m.

Drawing 2

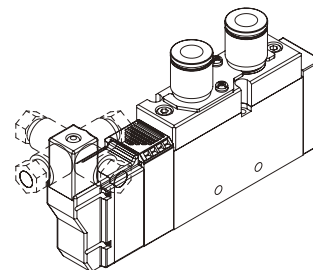

Installation & Adjustment

9. Port filter

⚠ CAUTION

■ Port filter is used to prevent foreign materials from entering, and problems in a valve. This does not improve the quality of compressed air, so read Warnings and Precautions in the General Pneumatic Valve Catalog (No. CB-023SA), and set up, install, and adjust the filter.

Do not remove or force the port filter.

The filter could deform and result in problems. If contaminants and foreign materials are found on the filter surface, flash lightly, or remove them by tweezers, etc.,

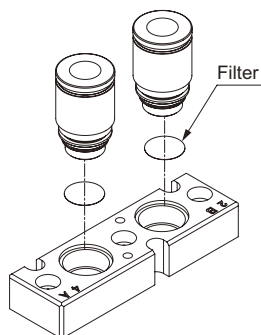

Example of integrating A/B port filter option

M4G^A4 Series

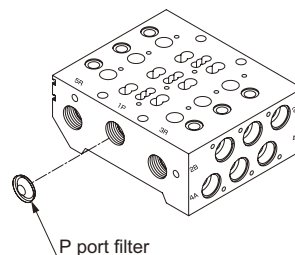

Example of integrating P port filter (standard)

M4GB4 Series

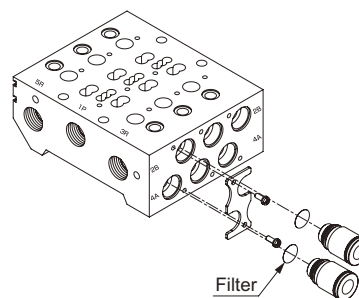

Example of integrating A/B port filter (option)

During Use & Maintenance

1. Common

⚠ WARNING

■ If valves are assembled or disassembled, read the instruction manual of the product very well and understand the contents before disassembling and assembling the product.

- Understand the structure and operational principle of the solenoid valve to secure safety.
- The grade not less than Pneumatics technique certification grade 2 is required.

⚠ CAUTION

■ Energizing for a long time could impair solenoid valve performance. Similar caution is required in the following use.

- During intermittent energizing, energizing takes longer than non-energizing.
- During intermittent energizing, one energizing session exceeds 30 min. Consider heat dissipation when installing.

■ If an pre-lubricated valve is once lubricated, oil-free property can not be maintained.

Once lubricated, continue the lubrication.

- Pneumatic components to be oil-free or to be lubricated and either lubrication method are determined to use, and the operation should be accurately controlled.
- Lubricant other than turbine oil Class 1 ISO VG32 (additive-free) can not be used for lubricating type.

2. Manual override

⚠ WARNING

■ 4G^A4 series is an internal pilot operated solenoid valve. If air is not supplied to the P port, the main valve will not change even if manual override is operated.

■ A protective cover of manual override is provided as standard. The manual override protective cover is closed when the valve is shipped to protect manual override, which cannot be seen when delivered. Open the protective cover and operate manual override.

Note that the protective cover does not close unless the manual override lock is released.

■ Manual override is used for both non-locking and locking. The lock is applied by pressing down and turning manual override. When locking, press down and turn. If manual override is turned without being pressed down, it could be damaged or air could leak.

■ Opening and closing the manual protective cover

Do not excessively force the manual protective cover when opening and closing it. Excessive force could cause faults. (Less than 5N)

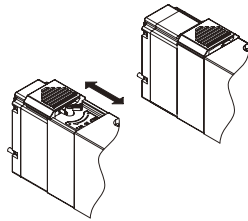

Slide type

■ How to operate manual override

● Push/non-locking operation

Push in the direction of the arrow until it stops. Manual override is unlocked when released.

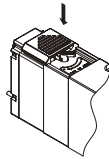

● Operating push/locking type

Push manual override and turn 90° in the direction of the arrow. Manual override is not unlocked even when released.

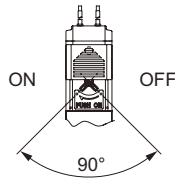
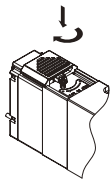

■ When conducting manual operations, make sure that there are no people near the moving cylinder.

3. How to replace cartridge joint

⚠ CAUTION

■ Check procedures before changing the push-in joint size. Improper installation or improper tightening of the set screws may result in air leaks.

■ Body porting (A) type

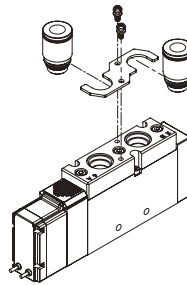

- ① Remove the set screw.
- ② Pull the stopper plate and joint out together.
- ③ Align the replacement joint groove with the stopper plate, and temporarily assemble.
- ④ Assemble the stopper plate and joint together, and tighten the set screw. Pull on the joint to confirm that it is installed.

	Size	Tightening Torque (N·m)
4G4	M3	0.6

■ Sub-base porting (B) type

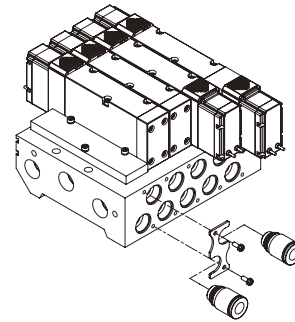

- ① Remove the set screw.
- ② Pull the stopper plate and joint out together.
- ③ Align the replacement joint groove with the stopper plate, and temporarily assemble.
- ④ Assemble the stopper plate and joint together, and tighten the set screw. Pull on the joint to confirm that it is installed.

Cartridge type push-in joint model no.

Model	Part name	Model no.
4G4	ø8 axial	4G4-JOINT-C8
	ø10 axial	4G4-JOINT-C10
	ø12 axial	4G4-JOINT-C12

During Use & Maintenance

4. How to change connecting port specifications

⚠ CAUTION

- When replacing the plate or joint adaptor on the body, changing between port specifications and base piping specifications, or changing between the port push in joint specifications and female thread specifications, if the set screw is not tightened enough, air leaks could occur. Check that tightening torque is appropriate.

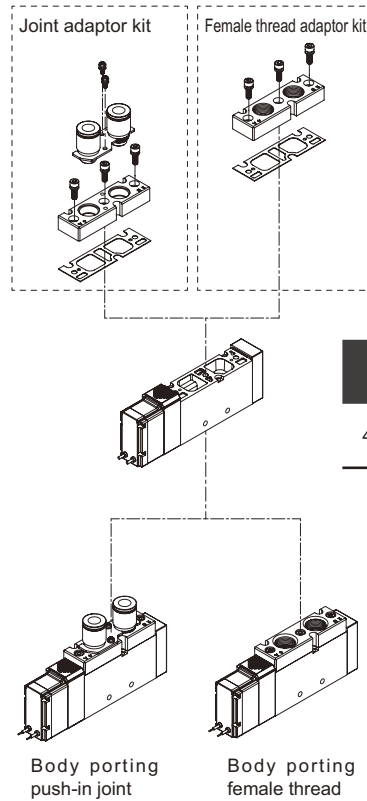

	Size	Tightening torque (N•m)
4G4	M3	0.6
	M4	2.2

Joint adaptor kit

Model	Part name	Kit model no.	Set part
4G4	ø8 joint adaptor kit	4GA4-JNT-ADAPTOR-KIT-C8- <input type="text" value="Option"/>	Joint adaptor Push-in joint 2 Joint stop plate Gasket Set screw 2 Adaptor set screw 3
	ø10 joint adaptor kit	4GA4-JNT-ADAPTOR-KIT-C10- <input type="text" value="Option"/>	
	ø12 joint adaptor kit	4GA4-JNT-ADAPTOR-KIT-C18- <input type="text" value="Option"/>	

Female thread adaptor kit

Model	Kit model no.	Set part
4G4	4GA4-FML-ADAPTOR-KIT- <input type="text" value="Port size"/> - <input type="text" value="Option"/>	Female thread adaptor, gasket and adaptor set screw 3

When using an A/B port filter integrated type, specify the in section "F".

MEMO

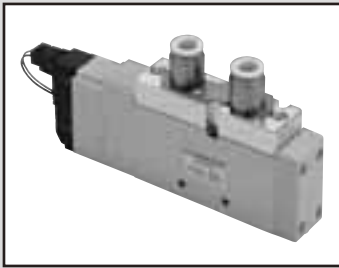

Discrete valve
Body porting

4GA4 Series

● Applicable cylinder bore size: $\varnothing 100$ to $\varnothing 140$

Common specifications

Descriptions	
Type of valve and operator type	Pilot operated soft spool valve
Working fluid	Compressed air
Max. working pressure MPa	0.7
Min. working pressure MPa	0.2 (2-position, 3-position)
Withstanding pressure MPa	1.05
Ambient temperature $^{\circ}\text{C}$	-5 to 55 (no freezing)
Fluid temperature $^{\circ}\text{C}$	5 to 55
Manual override	Non-locking/locking common type
Lubrication Note 1	Not required
Protective structure Note 2	Dust proof
Vibration/shock m/s^2	50 or less/300 or less
Working environment	Use in the environment containing corrosive gas is not permissible.

Note 1: Use the turbine oil Class 1 ISOVG 32 if lubricated.

Excessive or intermittent lubrication results in instable operation.

Note 2: Check that water drops or oil, etc., do not come into contact.

IP65 (jet-proof type) is used for DIN terminal box specifications.

Note that the box must be fixed using the specified adaptive cord outer diameter and tightening torque.

Electric specifications

Descriptions		
Rated voltage V	DC	12, 24
	AC	100, 110
Rated voltage fluctuation range		$\pm 10\%$
Holding current A Note 3	12 VDC	0.079 (0.083)
	24 VDC	0.040 (0.042)
	100 VAC	0.023 (0.024)
	110 VAC	0.023 (0.024)
Power consumption W Note 3	12 VDC	0.95 (1.0)
	24 VDC	0.95 (1.0)
Apparent power VA	100 VAC	2.3 (2.4)
	110 VAC	2.5 (2.6)
Heat proof class		B
Surge suppressor		Option
Indicator		With indicator light (option)

Note 3: Values in parentheses include light.

JIS symbol

● 5 port valve

2-position single solenoid

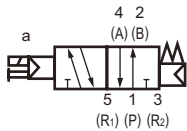

2-position double solenoid

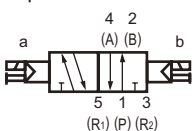

3-position

all ports closed

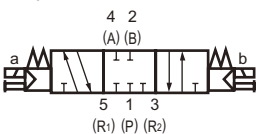

3-position A/B/R connection

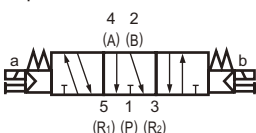

3-position P/A/B connection

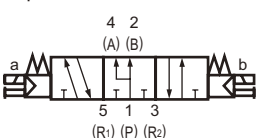

Individual specifications

Descriptions		4GA4
Port size	A/B port	Push-in joint $\varnothing 8$, $\varnothing 10$, $\varnothing 12$ Rc3/8, G3/8, NPT3/8
	P/R1/R2 port	Rc1/4, G1/4, NPT1/4

Descriptions			4GA4	
			When turned ON	When turned OFF
Response time ms	2-position	Single solenoid	40 (40)	40 (52)
		Double solenoid	40 (52)	40 (52)
	3-position	ABR connection	60 (72)	60 (72)

Values include the lamp surge suppressor. Response time is the value at an air supply of 0.5 MPa, 20 $^{\circ}\text{C}$, and oil-free. The value will change based on quality of pressure and oil. The value in () is for AC.

Descriptions		4GA4		
Weight g	2-position	Single solenoid	Grommet lead wire	DC 310 (319), AC 313 (322)
			E-connector	313 (322)
			DIN terminal box	322 (331)
		Double solenoid	Grommet lead wire	DC 371 (380), AC 377 (386)
			E-connector	377 (386)
			DIN terminal box	395 (404)
	3-position	All ports closed	Grommet lead wire	DC 402 (411), AC 408 (417)
			E-connector	408 (417)
			DIN terminal box	426 (435)

Values in parentheses include setscrews and the gasket. The E connector includes the socket assembly with a 300 mm lead. When using the EJ-connector, add 16 g per connector to the E connector value.

Flow characteristics

Model no.	Solenoid position		P → A/B		A/B → R1/R2	
			C [dm ³ /(s·bar)]	b	C [dm ³ /(s·bar)]	b
4GA4	2-position		8.1	0.40	8.0	0.31
	3-position	All ports closed	6.9	0.37	7.5	0.42
		ABR connection	6.8	0.40	8.7	0.37
		PAB connection	8.9	0.37	7.6	0.27

Note 1: Effective sectional area S and sonic conductance C are converted as $S \cong 5.0 \times C$.

Coolant proof specifications

Select with E Option "A" in How to order on page 3.

4GA4 Series

Discrete valve; body porting

How to order

4GA4 **1** **0** - **10** - **E2** - **3**

A Model no.

B Solenoid position

C Port size

D Electric connection

Refer to Intro 4 for a surge suppressor/indicator light circuit diagram.

E Option

F Voltage

A Model no.

4GA4

Symbol	Descriptions	
B Solenoid position		
1	2-position single solenoid	●
2	2-position double solenoid	●
3	3-position all ports closed	●
4	3-position ABR connection	●
5	3-position PAB connection	●
C Port size		
Port	A/B port	P/R port Rc1/4
C8	ø8 push-in joint	●
C10	ø10 push-in joint	●
C12	ø12 push-in joint	●
10	Rc3/8	●
10G	G3/8	● Note 1
10N	NPT3/8	● Note 2
D Electric connection		
Blank	Grommet lead wire	●
B	DIN terminal box (Pg7) with surge suppressor and indicator light	●
E-connector (radial/axial common)		
E0	Lead wire (300mm)	●
E00	Lead wire (500mm)	●
E01	Lead wire (1000mm)	●
E02	Lead wire (2000mm)	●
E03	Lead wire (3000mm)	●
E2	Lead wire (300mm) with surge suppressor and indicator light	●
E20	Lead wire (500mm) with surge suppressor and indicator light	●
E21	Lead wire (1000mm) with surge suppressor and indicator light	●
E22	Lead wire (2000mm) with surge suppressor and indicator light	●
E23	Lead wire (3000mm) with surge suppressor and indicator light	●
E0N	No lead wire (without socket)	●
E2N	No lead wire (without socket) with surge suppressor and indicator light	●
E3	No lead wire (socket and terminal attached) with surge suppressor and indicator light	●
E1	No lead wire (socket and terminal attached)	●
EJ-connector (socket with cover, up and axial common)		
E01J	Lead wire (1000mm)	●
E02J	Lead wire (2000mm)	●
E03J	Lead wire (3000mm)	●
E21J	Lead wire (1000mm) with surge suppressor and indicator light	●
E22J	Lead wire (2000mm) with surge suppressor and indicator light	●
E23J	Lead wire (3000mm) with surge suppressor and indicator light	●
E Option		
Blank	None	●
A	Coolant proof	●
F	A/B port filter integrated	●
F Voltage		
1	100 VAC (rectified bridge integrated)	●
3	24 VDC	●
4	12 VDC	●
5	110 VAC (rectified bridge integrated)	●

JIS symbol

● 5 port valve

2-position single solenoid

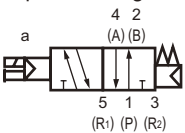

2-position double solenoid

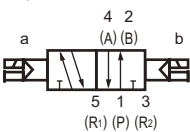

3-position

all ports closed

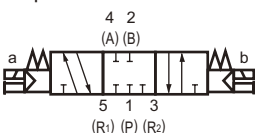

3-position A/B/R connection

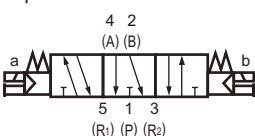

3-position P/A/B connection

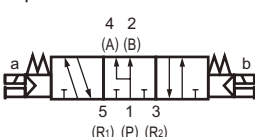

⚠ Note on model no. selection

Note 1: P/R port is G1/4.

Note 2: P/R port is NPT1/4.

MEMO

4GA4 Series

Discrete valve; body porting

Internal structure drawing and parts list

4GA410

- 2-position single solenoid
- Grommet lead wire (blank) DC specifications

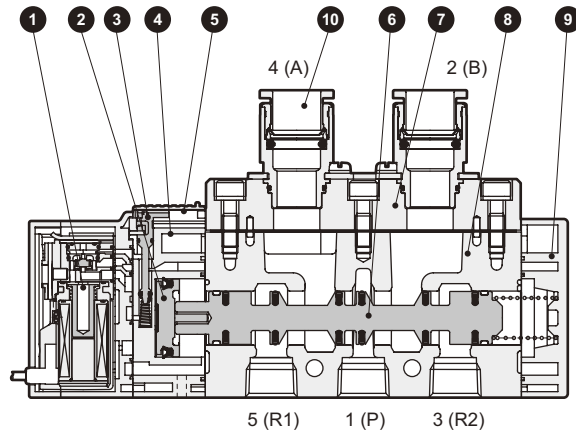
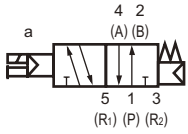

4GA420

- 2-position double solenoid
- Grommet lead wire (blank) DC specifications

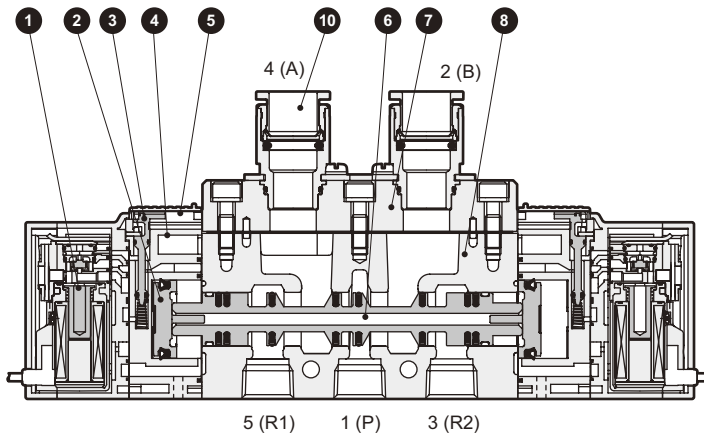
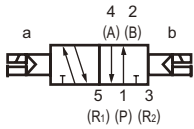

Internal structure drawing and parts list

4GA4³/₅0

● 3-position

Grommet lead wire (blank) DC specifications

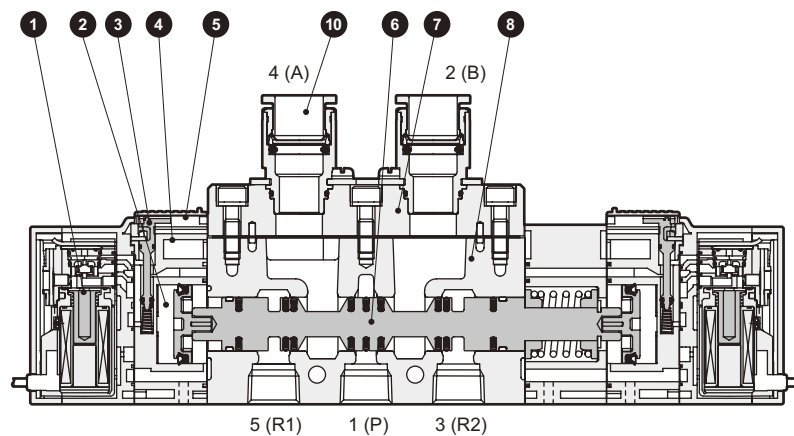
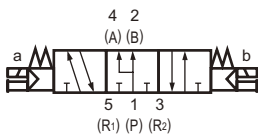
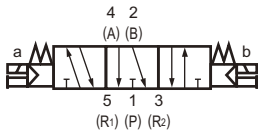
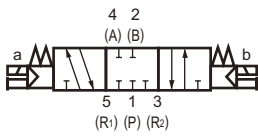

Main parts list

No.	Parts name	Material
1	Coil assembly	-
2	Piston assembly	-
3	Manual override	-
4	Piston room	PBT
5	Protective cover of manual override	PBT
6	Spool assembly	-
7	Joint adaptor	Aluminum
8	Body	Aluminum
9	Cap	PA
10	Cartridge type push-in joint	-

Repair parts list

No.	Parts name	Model no.
-	Cartridge type push-in joint and related parts	ø8 axial 4G4-JOINT-C8
		ø10 axial 4G4-JOINT-C10
		ø12 axial 4G4-JOINT-C12

4GA4 Series

Discrete valve; body porting

Internal structure drawing and parts list (electric connection)

- Grommet lead wire (blank) AC specifications

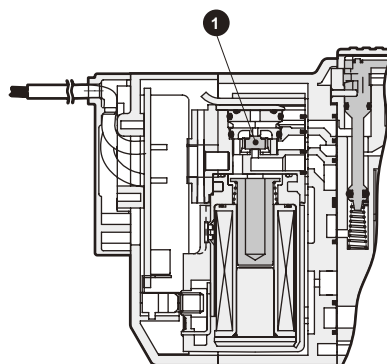

- E-connector type E**

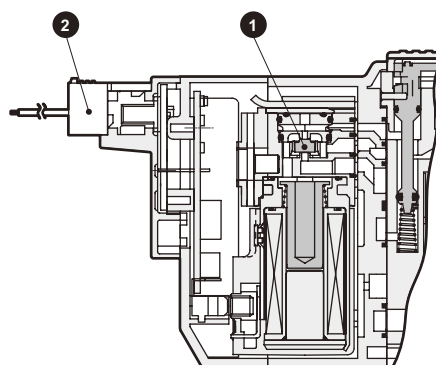

- EJ-connector type E** J

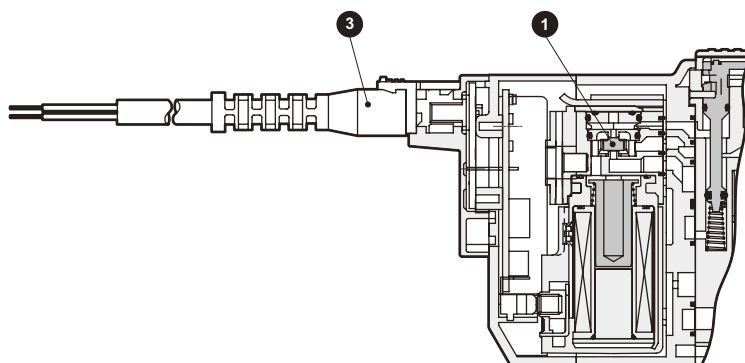

Internal structure drawing and parts list (electric connection)

● DIN terminal box type B

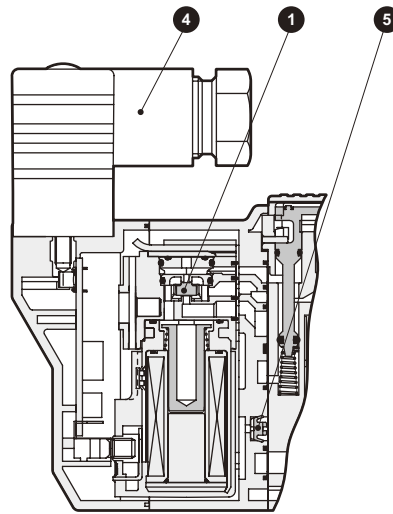

Main parts list

No.	Parts name	Material	No.	Parts name	Material
1	Coil assembly	-	4	DIN terminal box assembly	-
2	E-connector socket assembly	-	5	Check valve	NBR
3	Socket assembly with cover	-			

4GA4 Series

Discrete valve; body porting

Dimensions

4GA410

- 2-position single solenoid grommet lead wire (blank) DC specifications

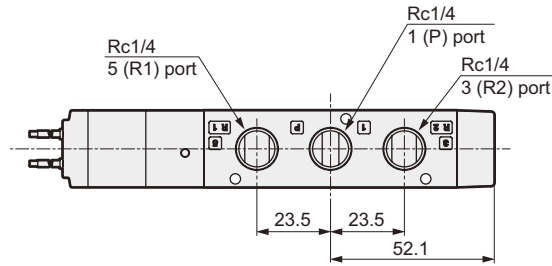
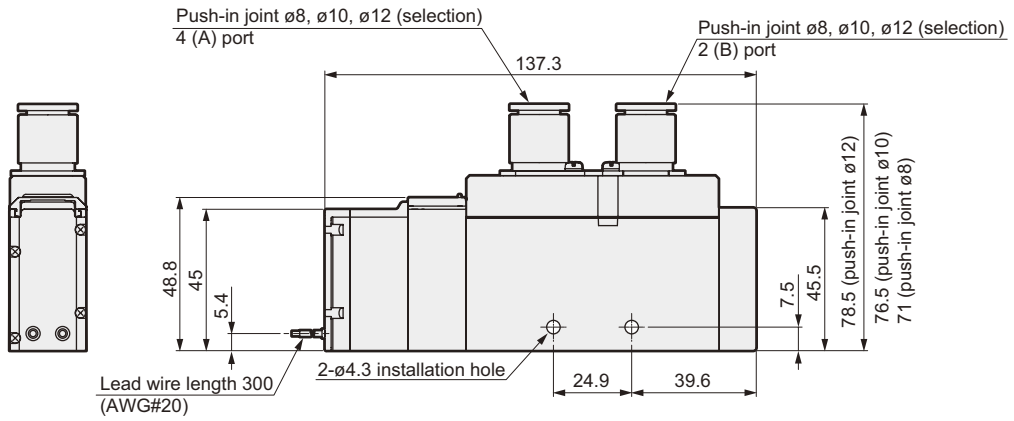
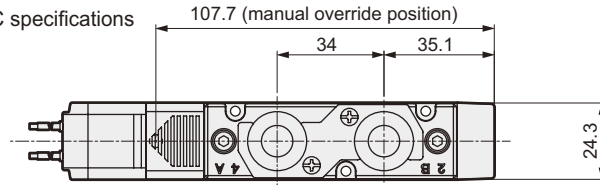
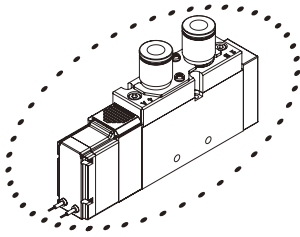

- Grommet lead wire (blank) AC specifications

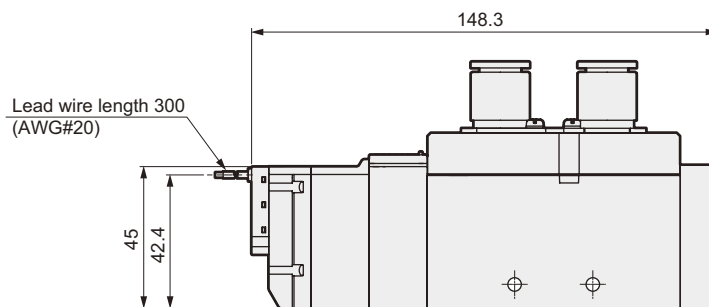
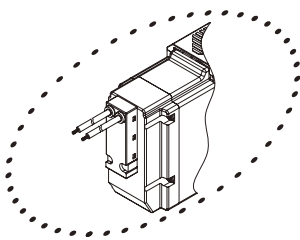

- Rc3/8 female thread type (10)

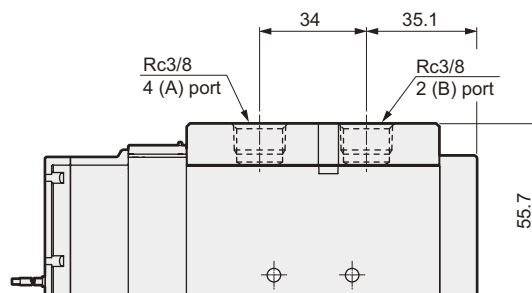
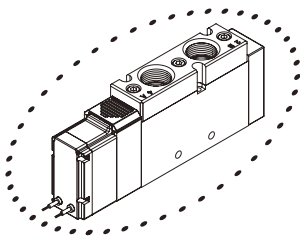

Dimensions

● E-connector type (E)

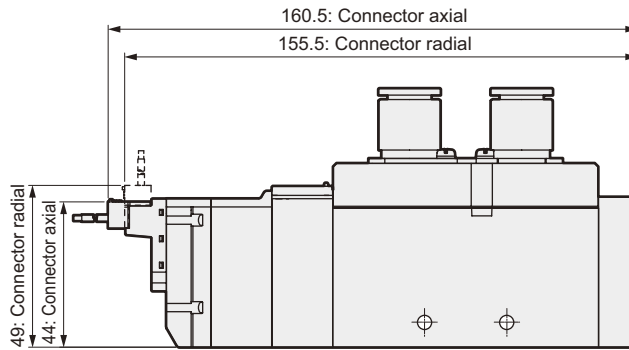
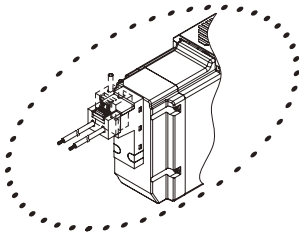

● EJ-connector type (E**J)

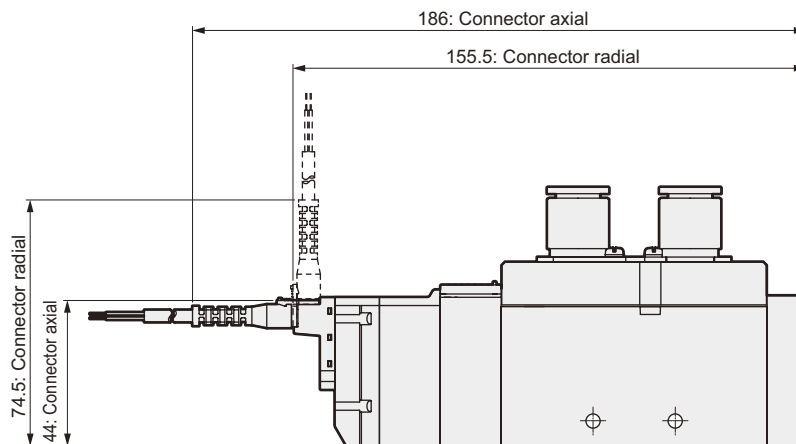
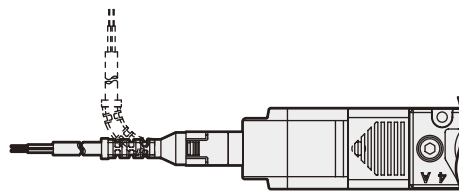
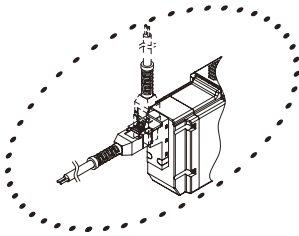

● DIN terminal box type (B)

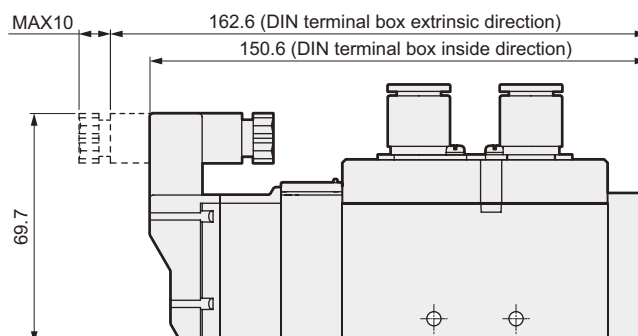
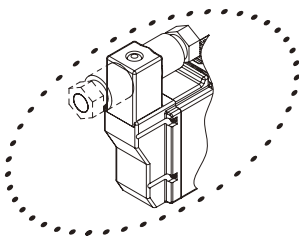

4GA4 Series

Discrete valve; body porting

Dimensions

4GA420

- 2-position double solenoid grommet lead wire (blank) DC specifications

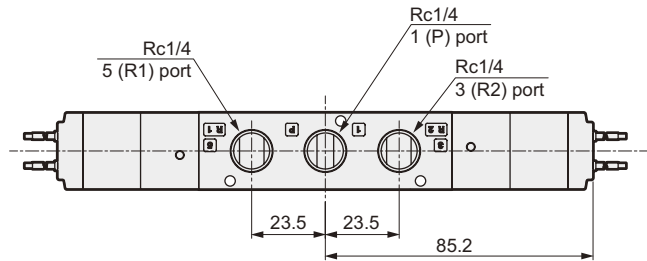
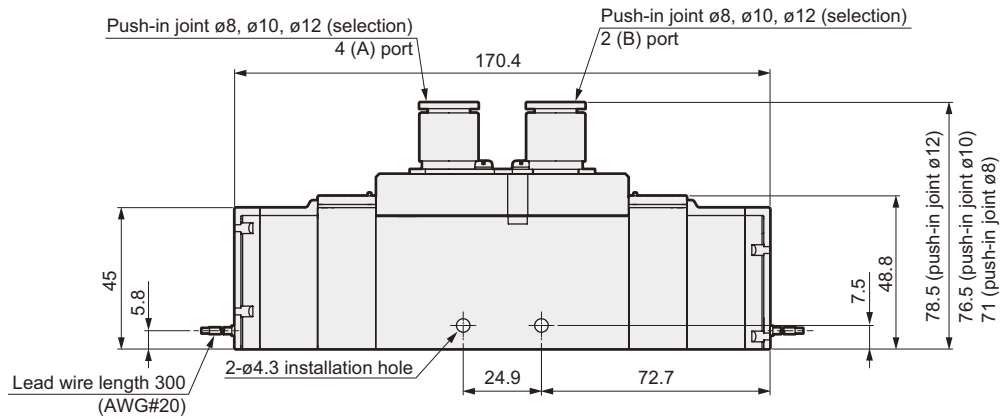
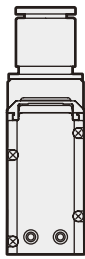
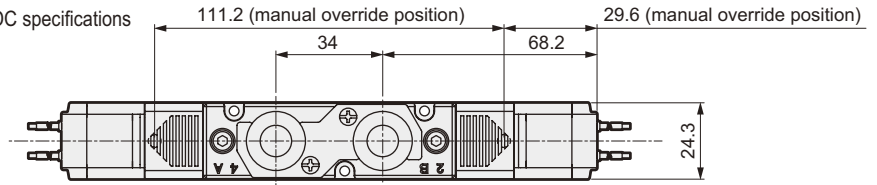
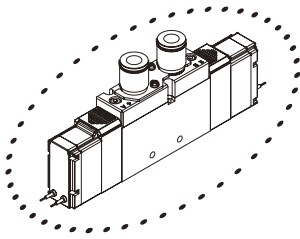

- Grommet lead wire (blank) AC specifications

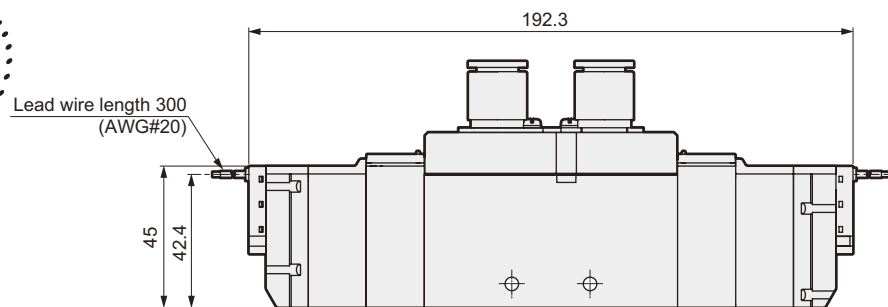
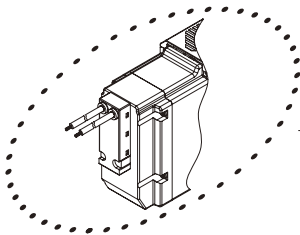

- Rc3/8 female thread type (10)

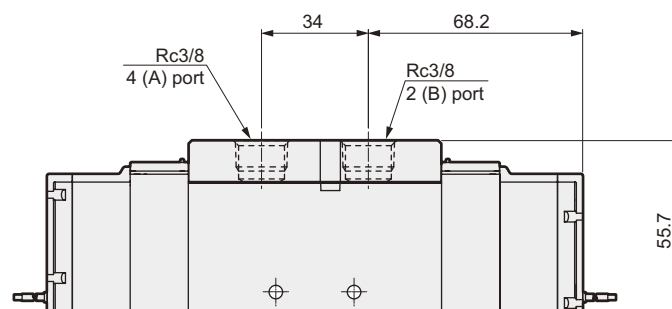
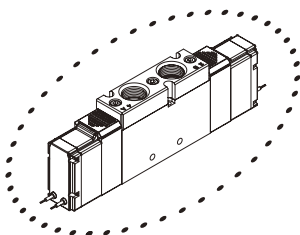

Dimensions

● E-connector type (E)

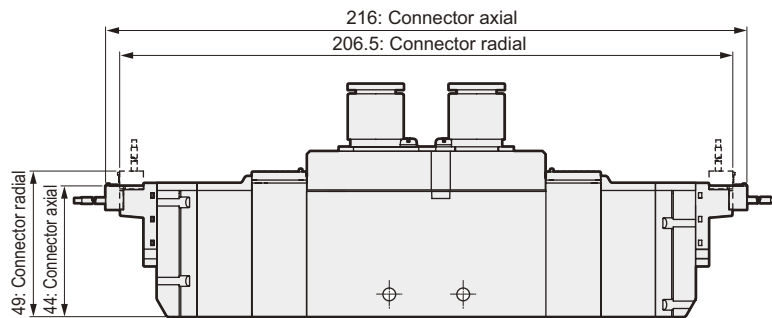
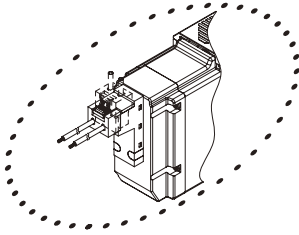

● EJ-connector type (E**J)

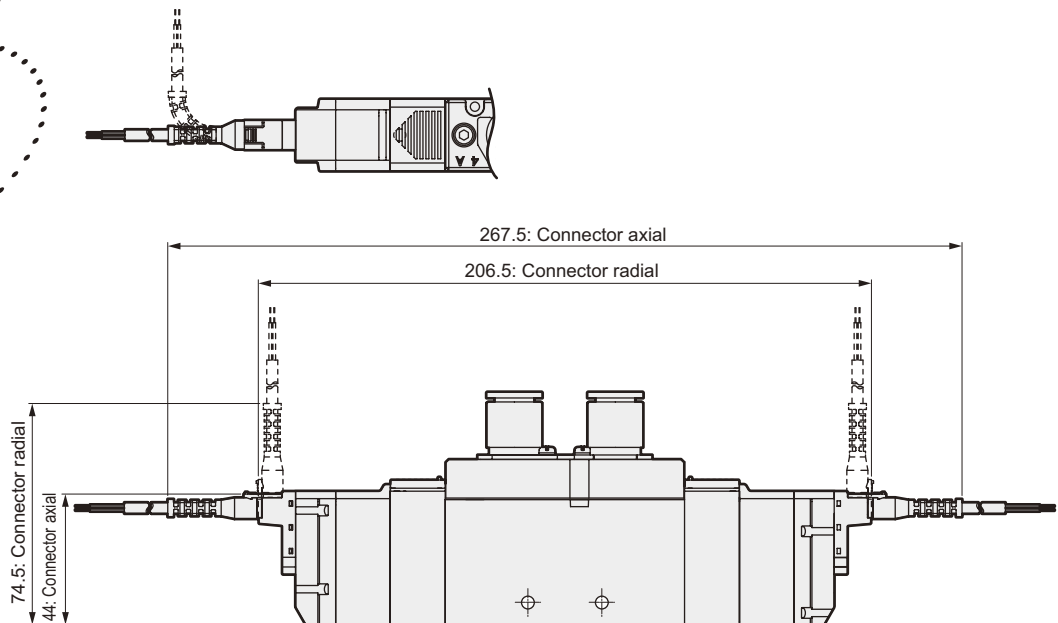
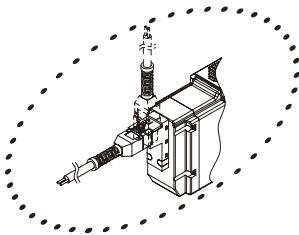

● DIN terminal box type (B)

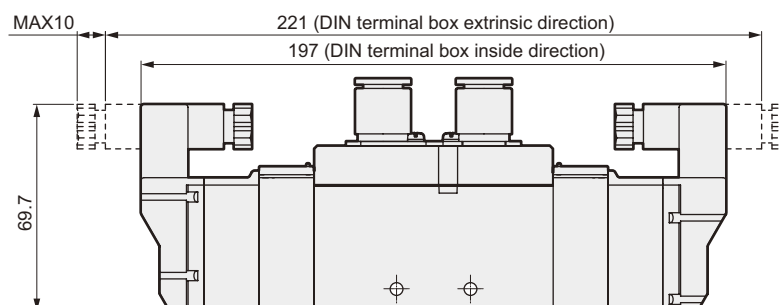
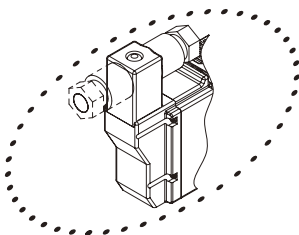

4GA4 Series

Discrete valve; body porting

Dimensions

4GA4³₄⁰

- 3 position grommet lead wire (blank) DC specifications

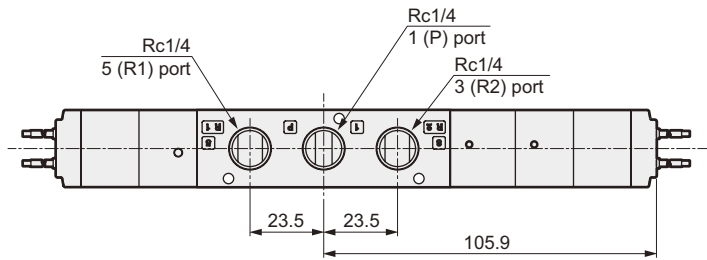
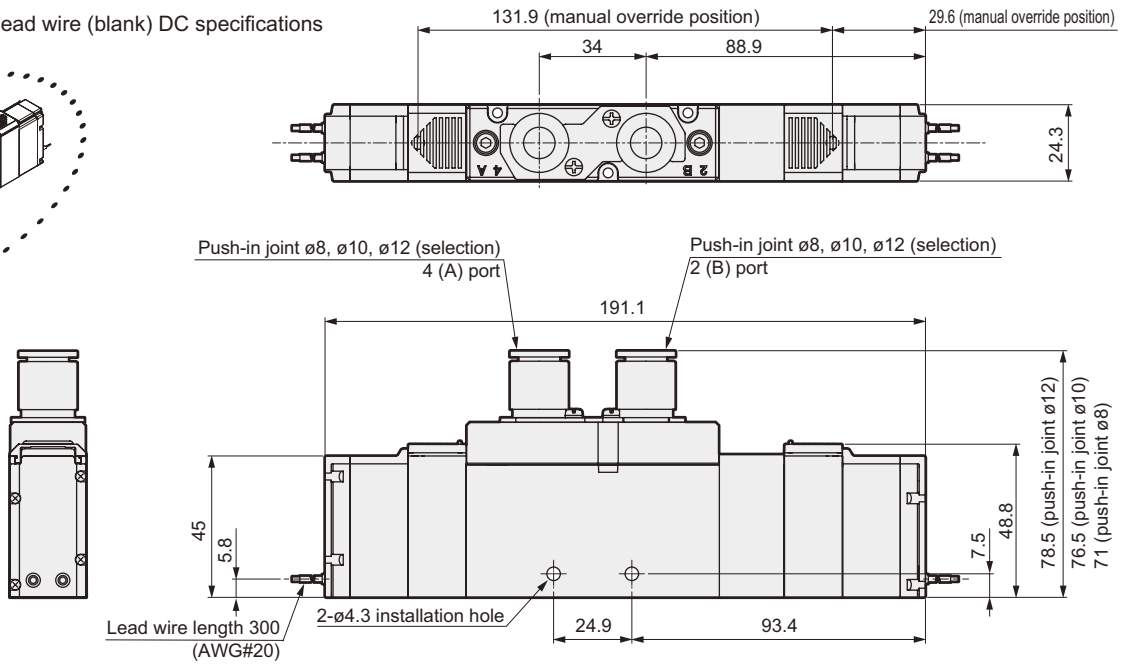
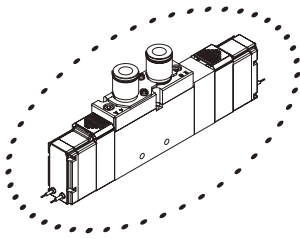

- Grommet lead wire (blank) AC specifications

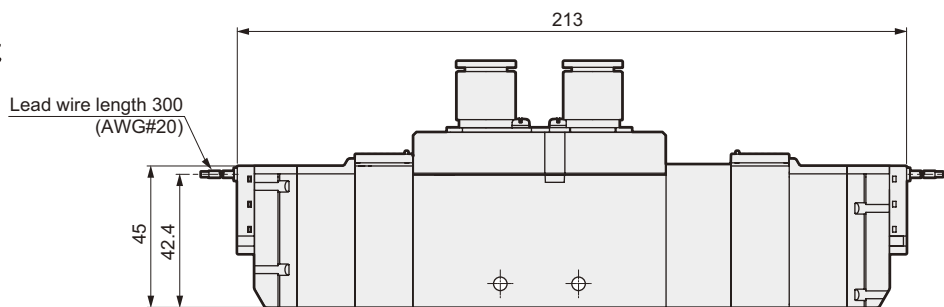
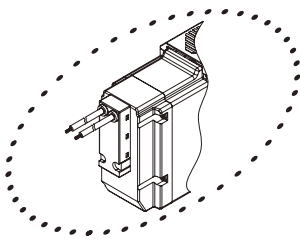

- Rc3/8 female thread type (10)

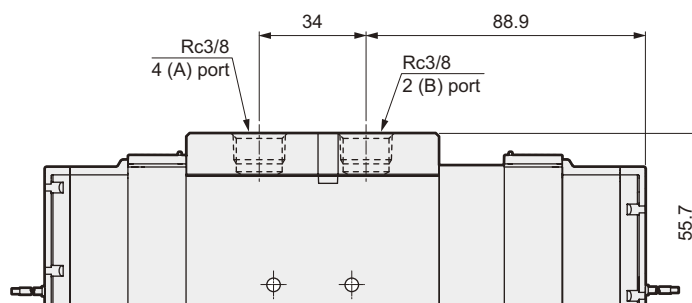
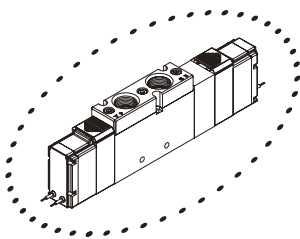

Dimensions

● E-connector type (E)

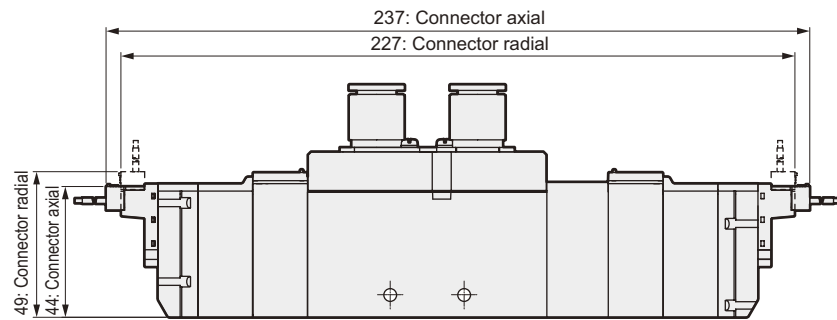
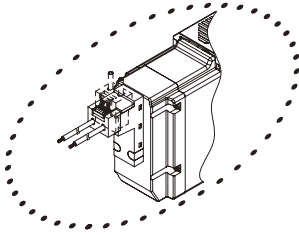

● EJ-connector type (E*J)

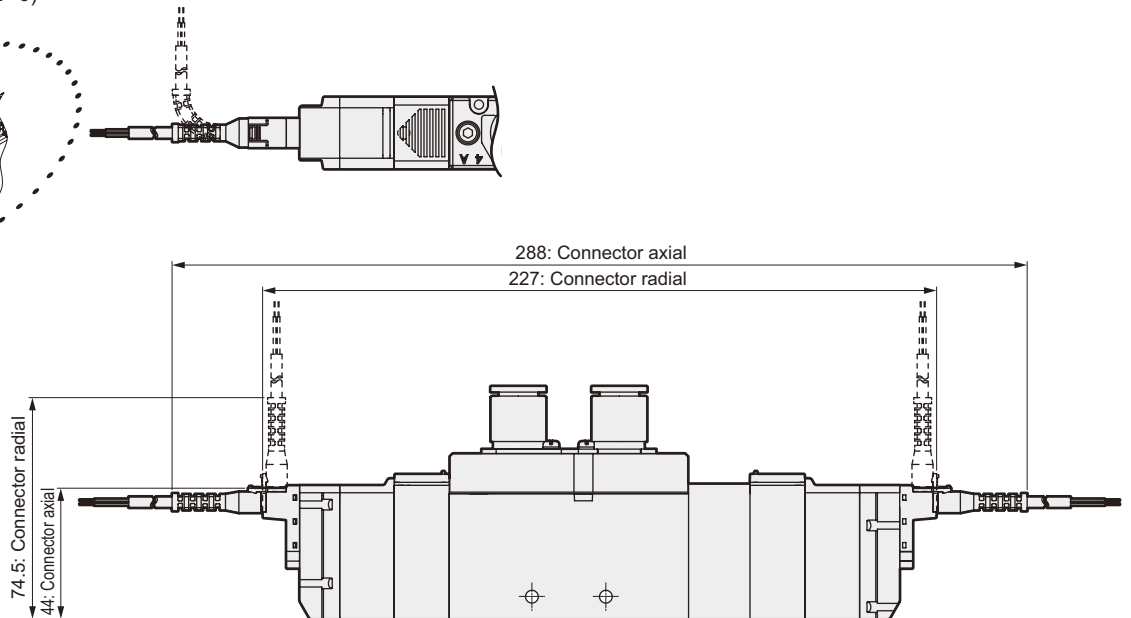
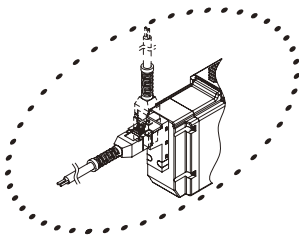

● DIN terminal box type (B)

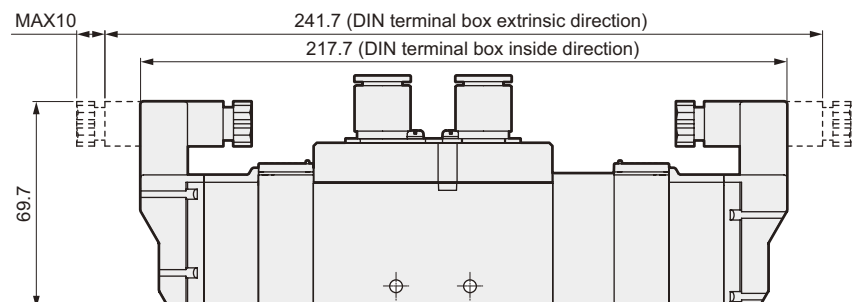
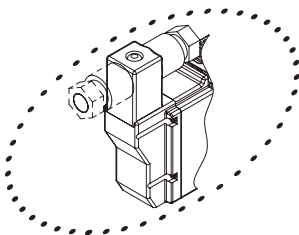

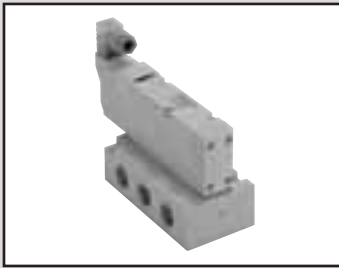

Discrete valve
Sub-base porting

4GB4 Series

● Applicable cylinder bore size: $\varnothing 125$ to $\varnothing 160$

Common specifications

Descriptions		
Type of valve and operator type	Pilot operated soft spool valve	
Working fluid	Compressed air	
Max. working pressure MPa	0.7	
Min. working pressure MPa	0.2 (2-position, 3-position)	
Withstanding pressure MPa	1.05	
Ambient temperature °C	-5 to 55 (no freezing)	
Fluid temperature °C	5 to 55	
Manual override	Non-locking/locking common type	
Pilot exhaust method	Internal pilot	Main valve, pilot valve common exhaust type
	External pilot	Main valve, pilot valve individual exhaust type
Lubrication	Note 1	Not required
Protective structure	Note 2	Dust proof
Vibration/shock	m/s ²	50 or less/300 or less
Working environment	Use in the environment containing corrosive gas is not permissible.	

Note 1: Use the turbine oil Class 1 ISOVG 32 if lubricated.

Excessive or intermittent lubrication results in instable operation.

Note 2: Check that water drops or oil, etc., do not come into contact.

IP65 (jet-proof type) is used for DIN terminal box specifications.

Note that the box must be fixed using the specified adaptive cord outer diameter and tightening torque.

Electric specifications

Descriptions		
Rated voltage	V	DC
		AC
Rated voltage fluctuation range		±10%
Holding current	A	12 VDC
		24 VDC
		100 VAC
		110 VAC
Power consumption	W	12 VDC
		24 VDC
Apparent power	VA	100 VAC
		110 VAC
Heat proof class		B
Surge suppressor		Option
Indicator		With indicator light (option)

Note 3: Values in parentheses include light.

JIS symbol

● 5 port valve

2-position single solenoid

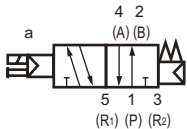

2-position double solenoid

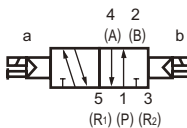

3-position

all ports closed

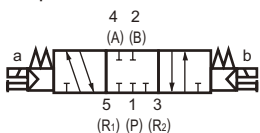

3-position A/B/R connection

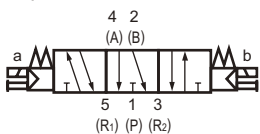

3-position P/A/B connection

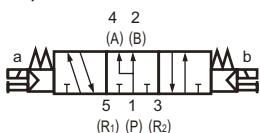

Individual specifications

Descriptions		4GB4
Port size	A/B port	Rc3/8, Rc1/2, G3/8, G1/2, NPT3/8, NPT1/2
	P/R1/R2 port	Rc3/8, Rc1/2, G3/8, G1/2, NPT3/8, NPT1/2

Descriptions		4GB4	
		When turned ON	When turned OFF
Response time	2-position	Single solenoid	40 (40)
		Double solenoid	40 (52)
	3-position	ABR connection	60 (72)

Values include the lamp surge suppressor. Response time is the value at an air supply of 0.5 MPa, 20°C, and oil-free. The value will change based on quality of pressure and oil. The value in () is for AC.

Descriptions		4GB4
Weight	g	Single solenoid
		Double solenoid
	2-position	Grommet lead wire
		E-connector
		DIN terminal box
	3-position	Grommet lead wire
		E-connector
		DIN terminal box

Values in parentheses do not include the piping adapter. The E connector includes the socket assembly with a 300 mm lead. When using the EJ-connector, add 16 g per connector to the E connector value.

Flow characteristics

Model no.	Solenoid position		P → A/B		A/B → R1/R2	
			C [dm ³ /(s·bar)]	b	C [dm ³ /(s·bar)]	b
4GB4	2-position		11	0.19	13	0.19
	3-position	All ports closed	9.1	0.11	12	0.27
		ABR connection	9.2	0.11	15	0.22
		PAB connection	10	0.06	12	0.24

Note 1: Effective sectional area S and sonic conductance C are converted as $S \cong 5.0 \times C$.

Coolant proof specifications

Select with E Option "A" in How to order on page 17.

4GB4 Series

Discrete valve; sub-base porting

How to order

4GB4 **1** **0** - **10** - **E2** - **3**

● A Model no.

● B Solenoid position

● C Port size

● D Electric connection
Refer to Intro 4 for a surge suppressor/indicator light circuit diagram.

● E Option

● F Voltage

A Model no.

4GB4

Symbol	Descriptions	
B Solenoid position		
1	2-position single solenoid	●
2	2-position double solenoid	●
3	3-position all ports closed	●
4	3-position ABR connection	●
5	3-position PAB connection	●

C Port size			
Port	A/B port	P/R port	
		Rc3/8	Rc1/2
10	Rc3/8	●	
15	Rc1/2		●
10G	G3/8	● Note 1	
15G	G1/2		● Note 1
10N	NPT3/8	● Note 2	
15N	NPT1/2		● Note 2

D Electric connection		
Blank	Grommet lead wire	●
B	DIN terminal box (Pg7) with surge suppressor and indicator light	●
E Connector (radial/axial common)		
E0	Lead wire (300mm)	●
E00	Lead wire (500mm)	●
E01	Lead wire (1000mm)	●
E02	Lead wire (2000mm)	●
E03	Lead wire (3000mm)	●
E2	Lead wire (300mm) with surge suppressor and indicator light	●
E20	Lead wire (500mm) with surge suppressor and indicator light	●
E21	Lead wire (1000mm) with surge suppressor and indicator light	●
E22	Lead wire (2000mm) with surge suppressor and indicator light	●
E23	Lead wire (3000mm) with surge suppressor and indicator light	●
E0N	No lead wire (without socket)	●
E2N	No lead wire (without socket) with surge suppressor and indicator light	●
E3	No lead wire (socket and terminal attached) with surge suppressor and indicator light	●
E1	No lead wire (socket and terminal attached)	●

EJ Connector (socket with cover, up and axial common)		
E01J	Lead wire (1000mm)	●
E02J	Lead wire (2000mm)	●
E03J	Lead wire (3000mm)	●
E21J	Lead wire (1000mm) with surge suppressor and indicator light	●
E22J	Lead wire (2000mm) with surge suppressor and indicator light	●
E23J	Lead wire (3000mm) with surge suppressor and indicator light	●

E Option		
Blank	None	●
K	External pilot	●
A	Coolant proof	●
F	A/B port filter integrated	●

F Voltage		
1	100 VAC (rectified bridge integrated)	●
3	24 VDC	●
4	12 VDC	●
5	110 VAC (rectified bridge integrated)	●

⚠ Note on model no. selection

Note 1: P/R port is G thread.

Note 2: P/R port is NPT thread.

JIS symbol

● 5 port valve

2-position single solenoid

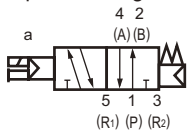

2-position double solenoid

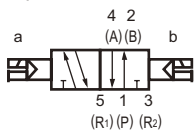

3-position

all ports closed

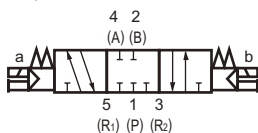

3-position A/B/R connection

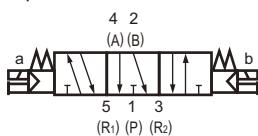

3-position P/A/B connection

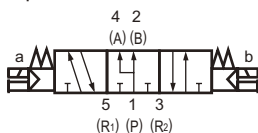

MEMO

4GB4 Series

Discrete valve; sub-base porting

Internal structure drawing and parts list

4GB410

- 2-position single solenoid
grommet lead wire (blank) DC specifications

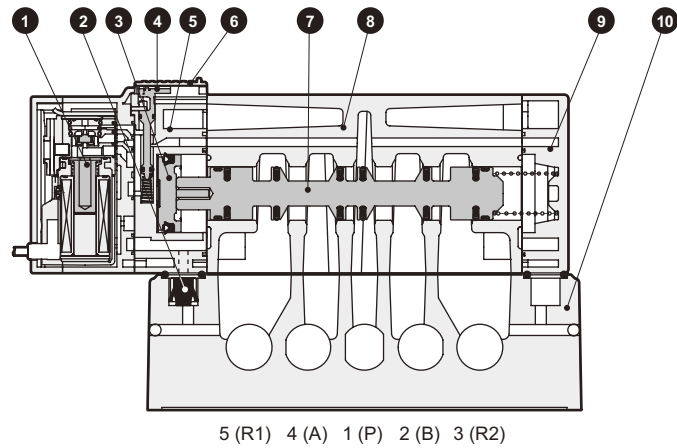
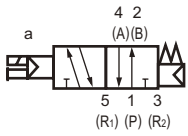

4GB420

- 2-position double solenoid
grommet lead wire (blank) DC specifications

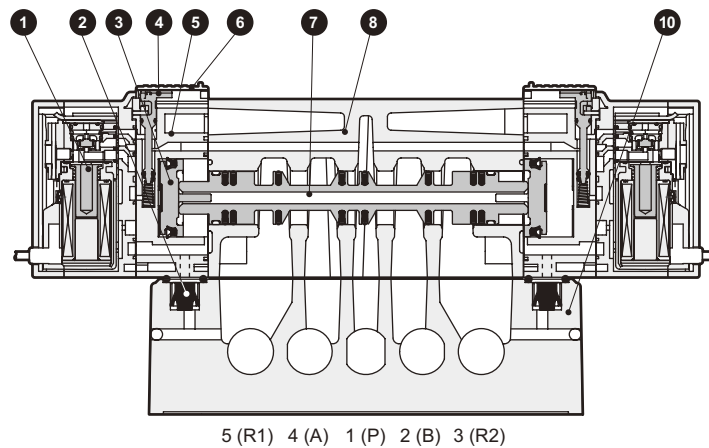
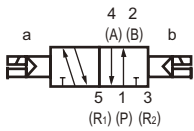

Internal structure drawing and parts list

4GB4 ³/₄ 0

● 3-position

grommet lead wire (blank) DC specifications

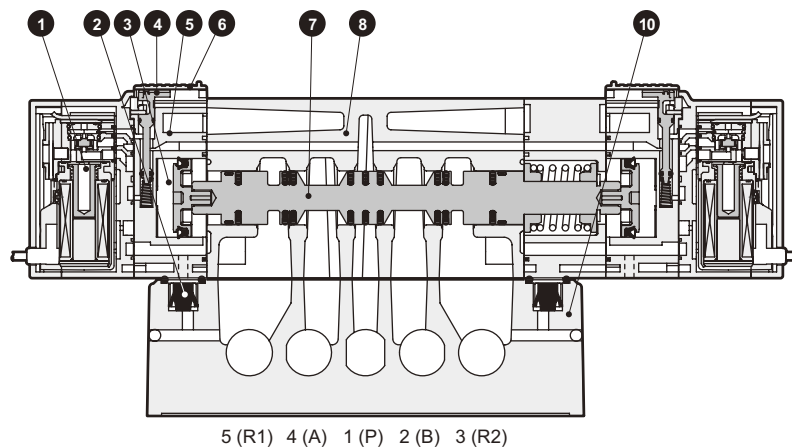
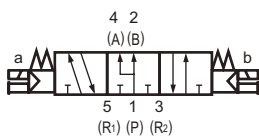
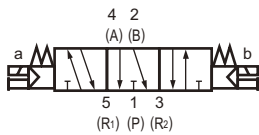
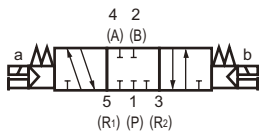

Main parts list

No.	Parts name	Material	No.	Parts name	Material
1	Coil assembly	-	6	Protective cover of manual override	PBT
2	Quick exhaust valve	H-NBR	7	Spool assembly	-
3	Piston assembly	-	8	Body	Aluminum
4	Manual override	-	9	Cap	PA
5	Piston room	PBT	10	Discrete sub-base	Aluminum

4GB4 Series

Discrete valve; sub-base porting

Internal structure drawing and parts list (electric connection)

- Grommet lead wire (blank) AC specifications

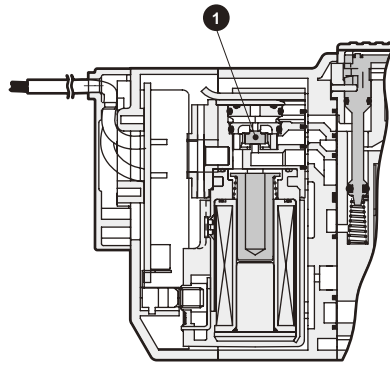

- E-connector type E**

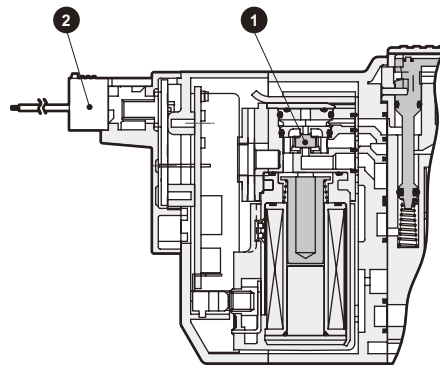

- EJ-connector type E** J

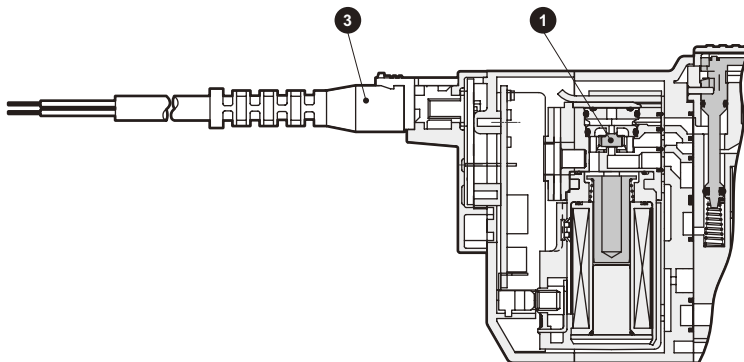

Internal structure drawing and parts list (electric connection)

● DIN terminal box type B

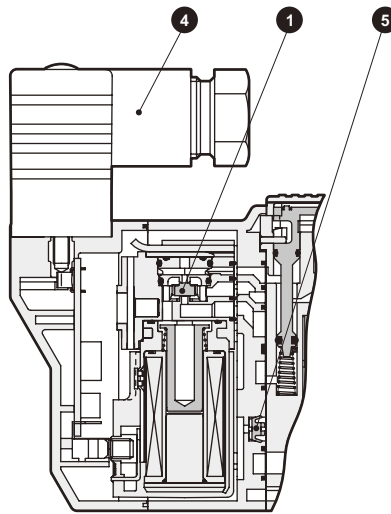

Main parts list

No.	Parts name	Material	No.	Parts name	Material
1	Coil assembly	-	4	DIN terminal box assembly	-
2	E-connector socket assembly	-	5	Check valve	NBR
3	Socket assembly with cover	-			

4GB4 Series

Discrete valve; sub-base porting

Dimensions

4GB410

- 2-position single solenoid grommet lead wire (blank) DC specifications

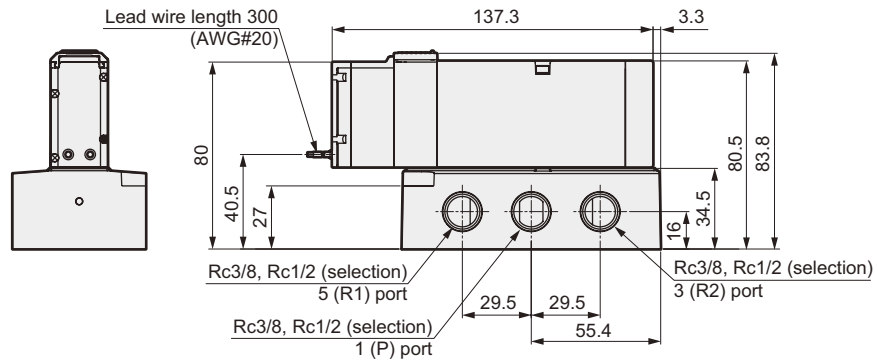
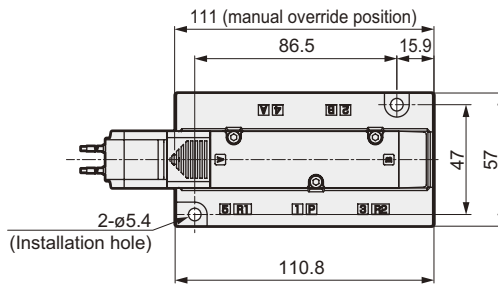
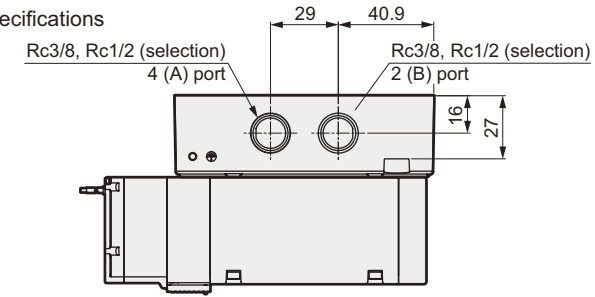
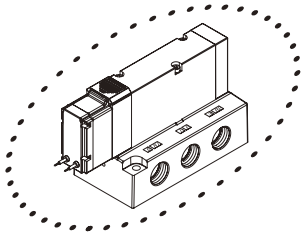

- Grommet lead wire (blank) AC specifications

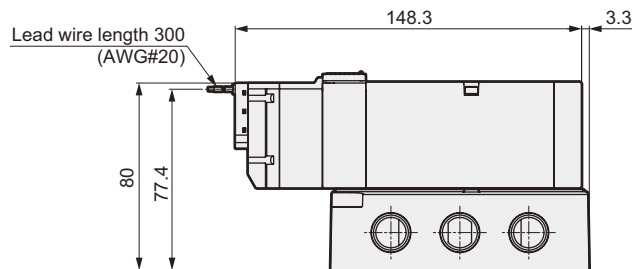
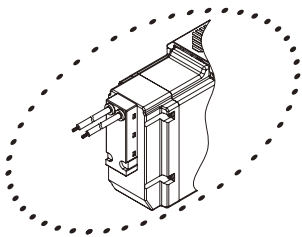

- External pilot operated (K)

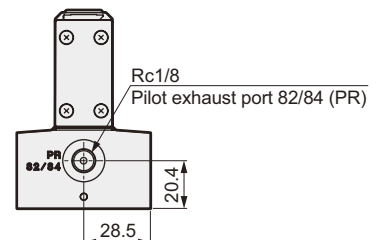
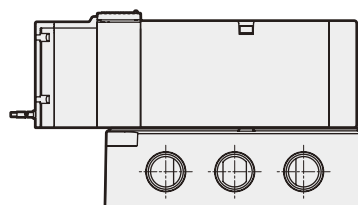
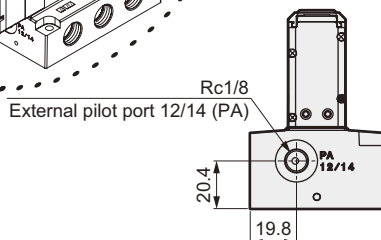
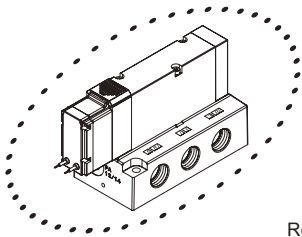

Dimensions

● E-connector type (E)

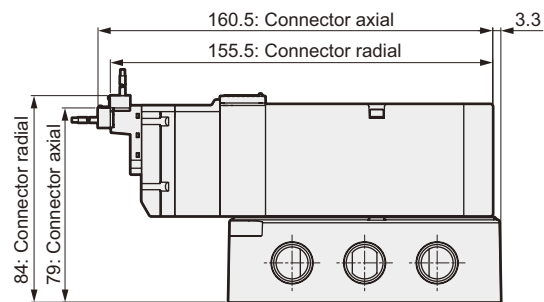
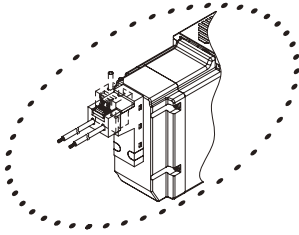

● EJ-connector type (E*J)

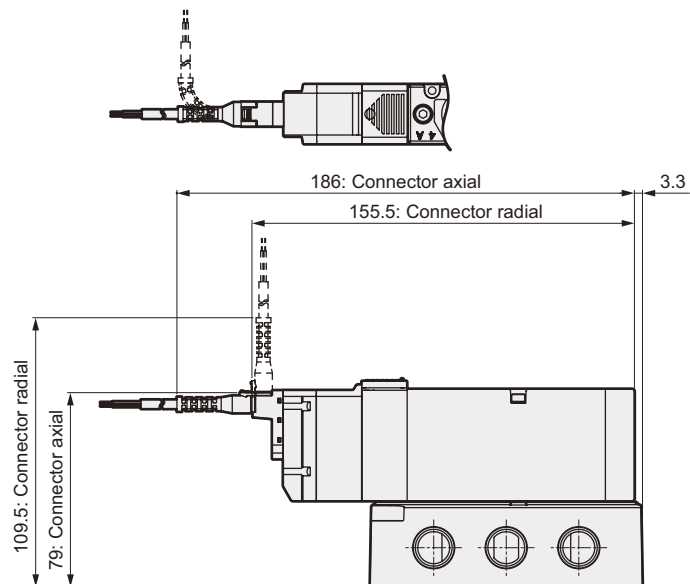
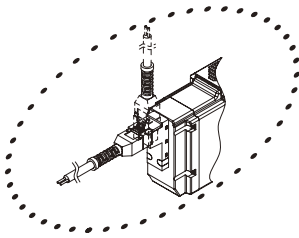

● DIN terminal box type (B)

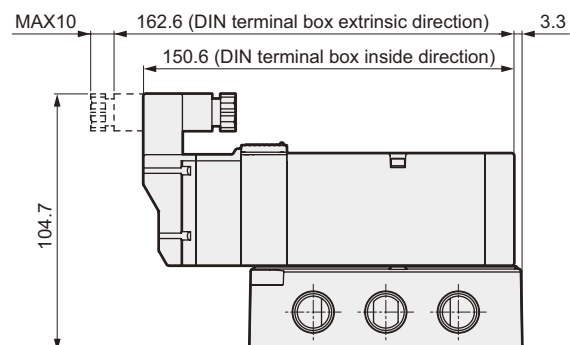
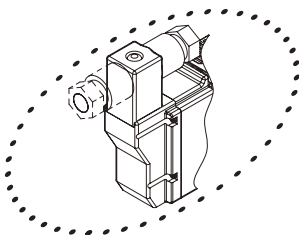

4GB4 Series

Discrete valve; sub-base porting

Dimensions

4GB420

- 2-position double solenoid grommet lead wire (blank) DC specifications

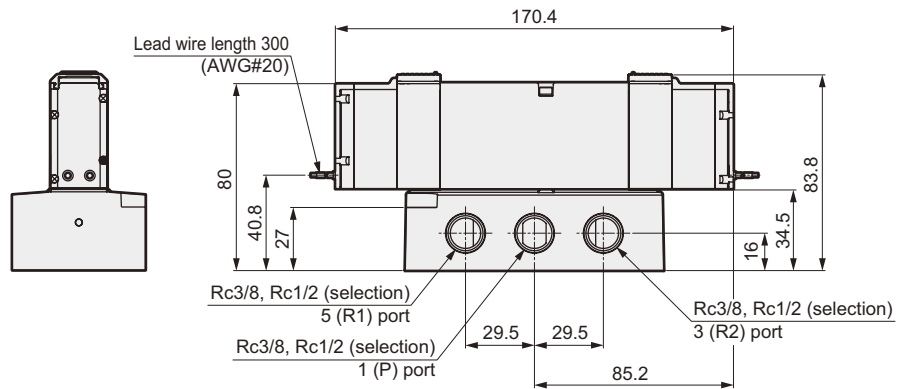
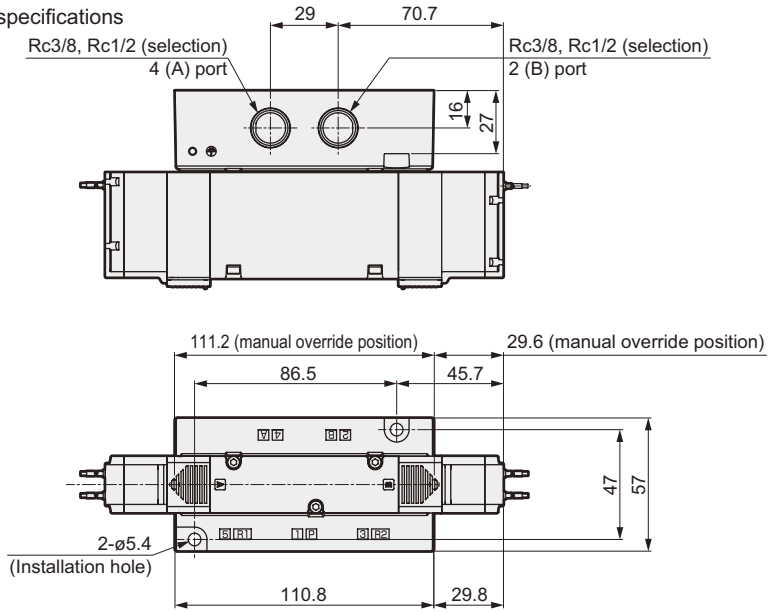
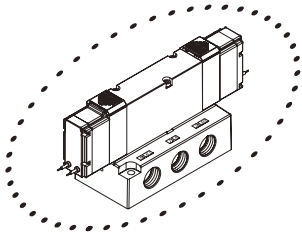

- Grommet lead wire (blank) AC specifications

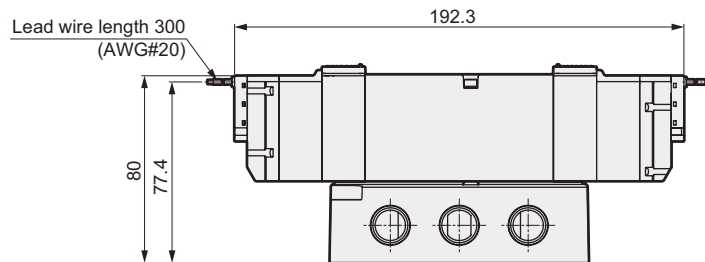
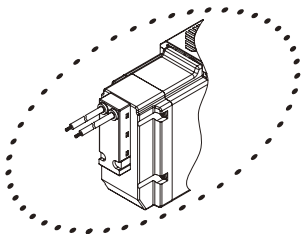

- External pilot operated (K)

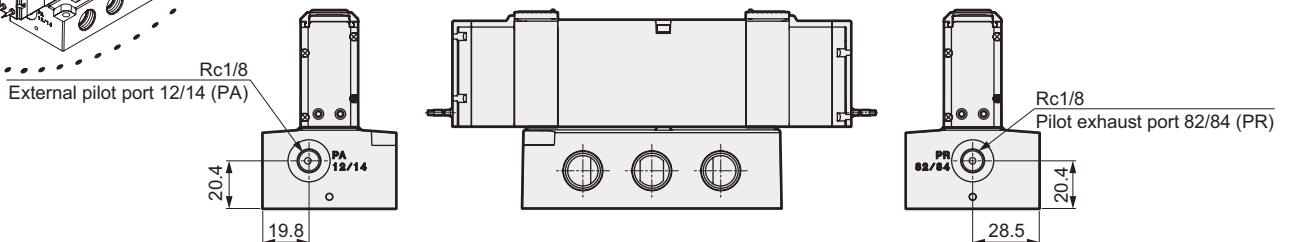
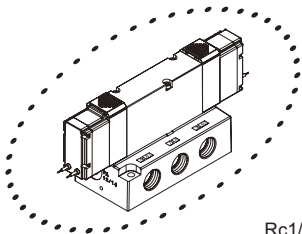

Dimensions

● E-connector type (E)

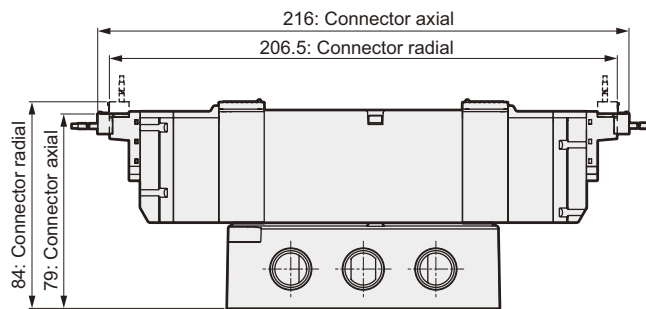
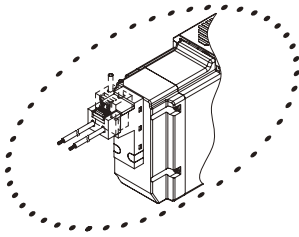

● EJ-connector type (E**J)

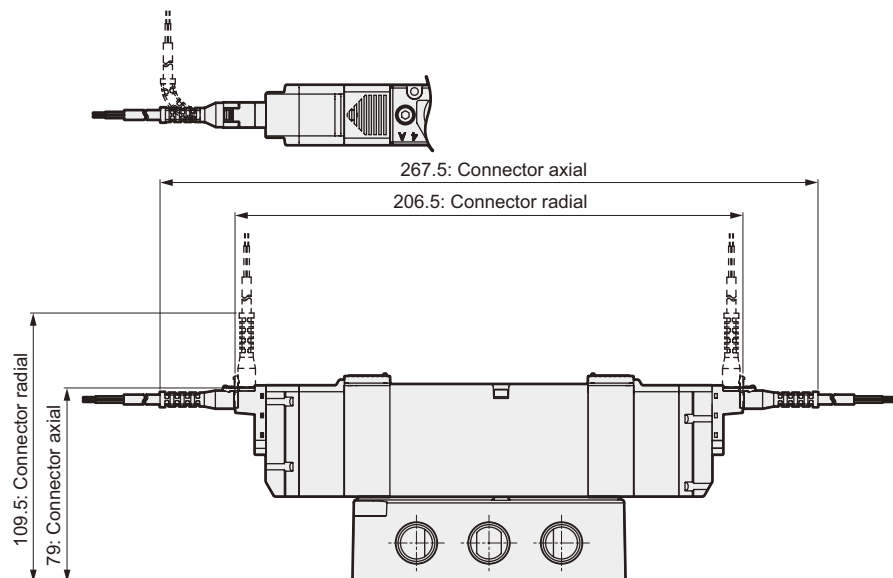
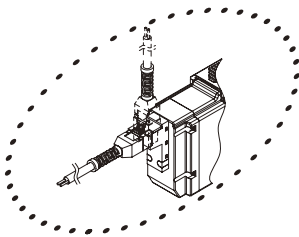

● DIN terminal box type (B)

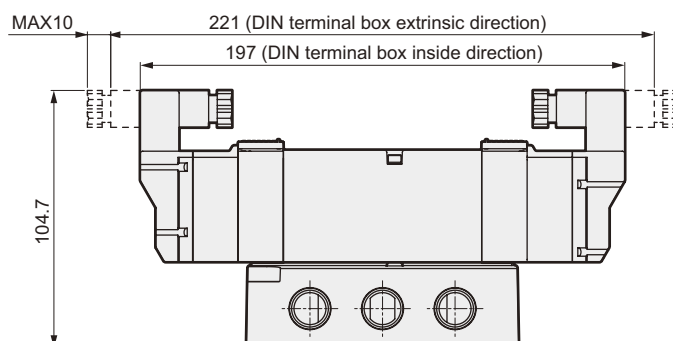
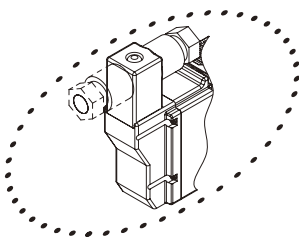

4GB4 Series

Discrete valve; sub-base porting

Dimensions

4GB4³/₄/₅0

- 3-position grommet lead wire (blank) DC specifications

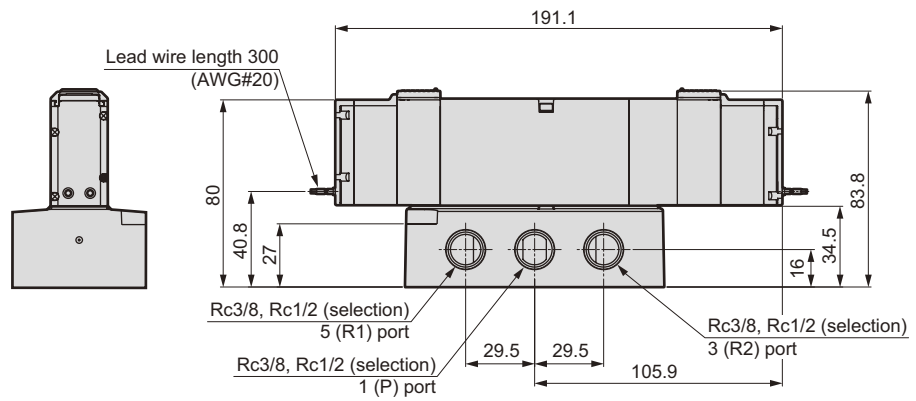
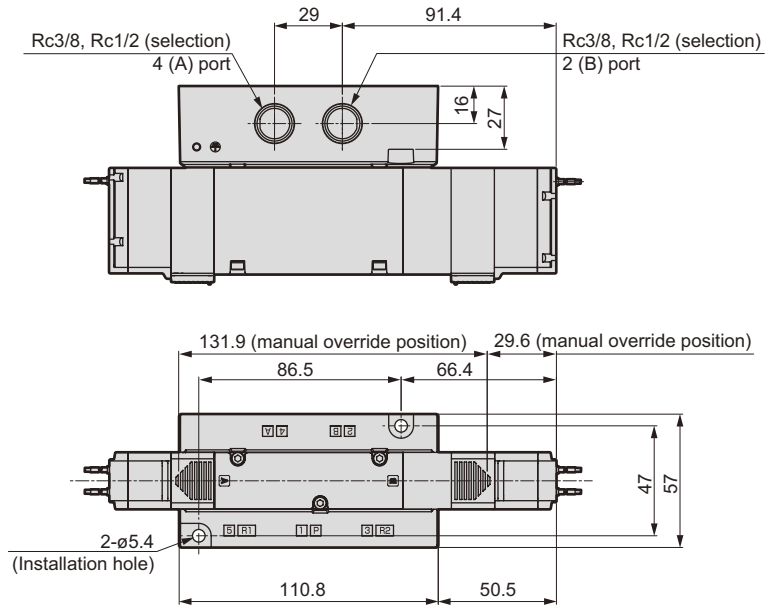
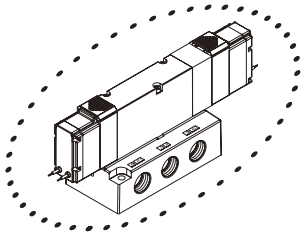

- Grommet lead wire (blank) AC specifications

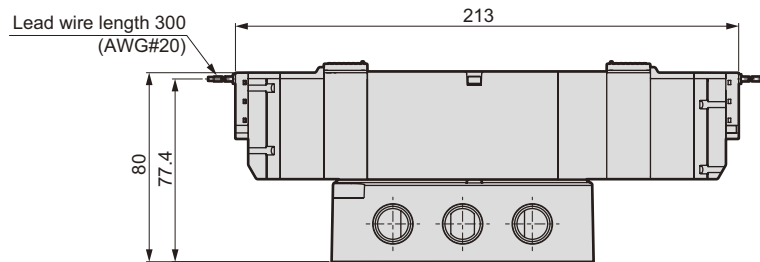
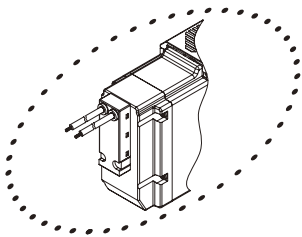

- External pilot operated (K)

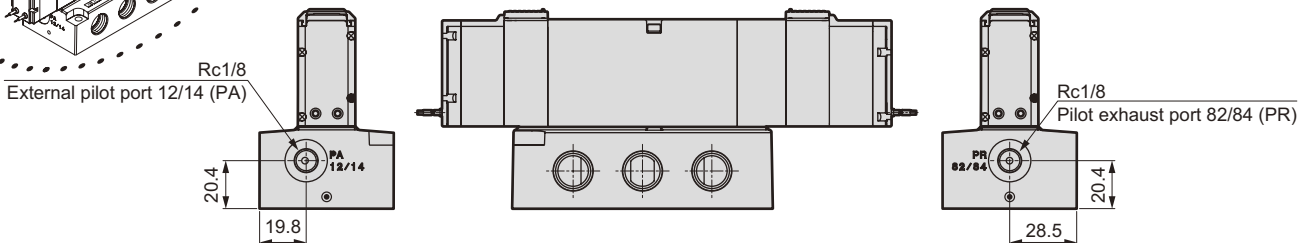
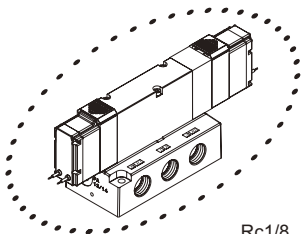

Dimensions

● E-connector type (E)

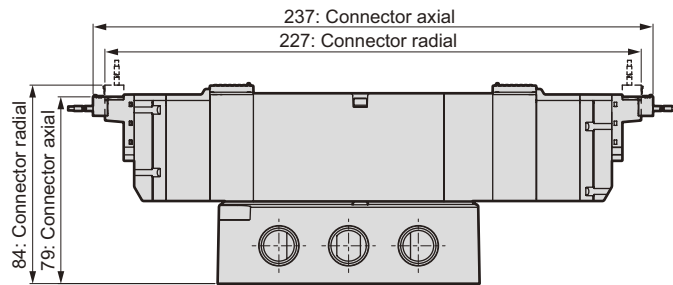
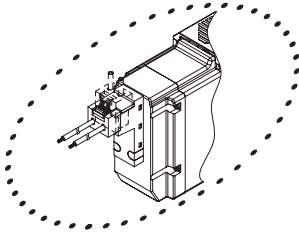

● EJ-connector type (E**J)

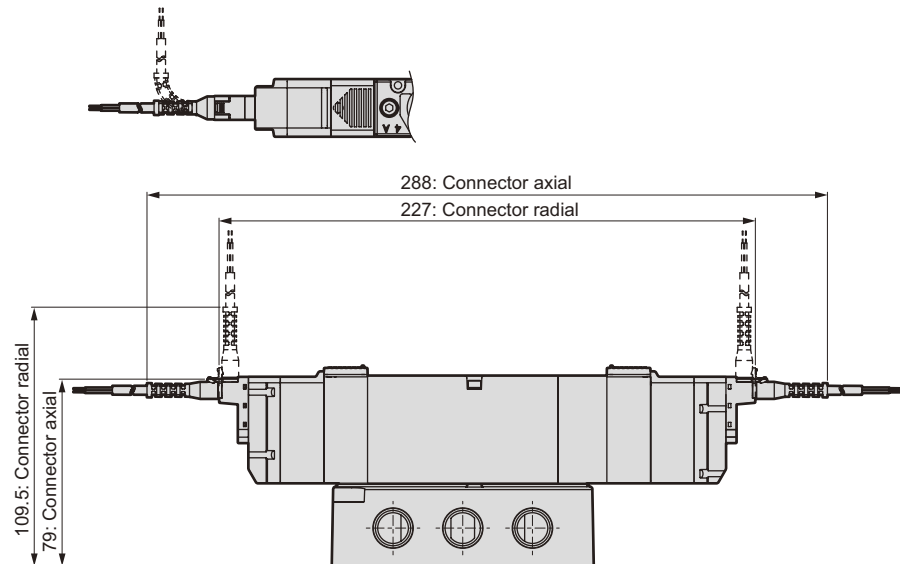
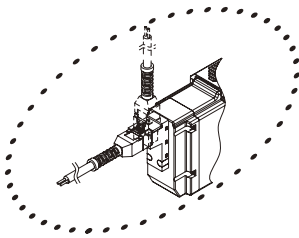

● DIN terminal box type (B)

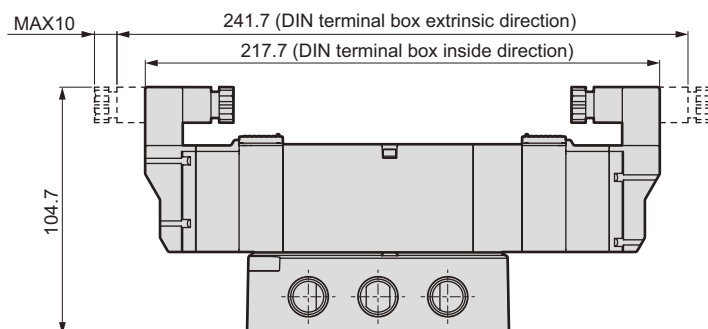
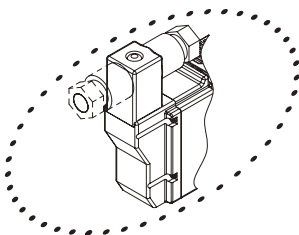

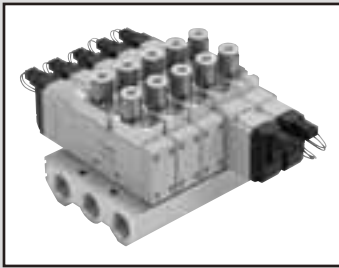

Individual wiring type manifold
Body porting
Direct mount type

M4GA4 Series

● Applicable cylinder bore size: $\varnothing 100$ to $\varnothing 140$

Common manifold specifications

Descriptions		
Manifold type		Integrated base
How to install the product		Direct mount type
Air supply and exhaust method		Common supply and common exhaust
Pilot exhaust method	Internal pilot	Main valve and pilot valve common exhaust (Pilot exhaust check valve integrated)
	External pilot	Main valve and pilot valve individual exhaust
Piping direction		Valve top direction
Type of valve and operator type		Pilot operated soft spool valve
Working fluid		Compressed air
Max. working pressure	MPa	0.7
Min. working pressure	MPa	0.2 (2-position, 3-position)
Withstanding pressure	MPa	1.05
Ambient temperature	°C	-5 to 55 (no freezing)
Fluid temperature	°C	5 to 55
Manual override		Non-locking/locking common type
Lubrication	Note 1	Not required
Protective structure	Note 1	Dust proof
Vibration/shock	m/s ²	50 or less/300 or less
Working environment		Use in the environment containing corrosive gas is not permissible.

Note 1: Use the turbine oil Class 1 ISOVG 32 if lubricated. When lubricated excessively or intermittently, the operation could result in unstable.

Note 2: Check that water drops or oil, etc., do not come into contact.

IP65 (jet-proof type) is used for DIN terminal box specifications. Note that the box must be fixed using the specified adaptive cord outer diameter and tightening torque.

Note 3: External pilot pressure when the external pilot (option symbol: K) is selected must be within the minimum/maximum working pressure range of the individual model. Note that it must be higher than the main valve working pressure.

JIS symbol

● 5 port valve

2-position single solenoid

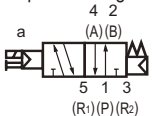

2-position double solenoid

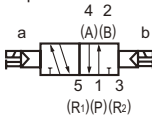

3-position

all ports closed

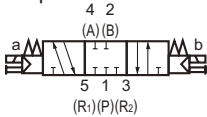

3-position A/B/R connection

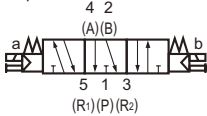

3-position P/A/B connection

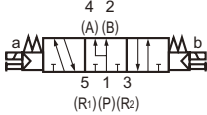

Individual specifications

Descriptions		M4GA4
		Direct mount
Maximum station number	Standard (internal pilot) External pilot	15 station
Port size	A/B port P/R1/R2 port	Push-in joint $\varnothing 8$, $\varnothing 10$, $\varnothing 12$ Rc3/8, G3/8, NPT3/8 Rc1/2, G1/2, NPT1/2
Manifold base	Standard	150n + 199
Weight calculation formula (n: Number of stations) g	External pilot	379n + 617

If there are more than five manifold stations, supply and exhaust from ports on both sides.
The manifold base weight is the value for screw specifications.

Electric specifications

Descriptions			
Rated voltage	V DC	12, 24	
	AC	100, 110	
Rated voltage fluctuation range		$\pm 10\%$	
Holding current	A	12 VDC	0.079 (0.083)
		24 VDC	0.040 (0.042)
		100 VAC	0.023 (0.024)
		110 VAC	0.023 (0.024)
Power consumption	W	12 VDC	0.95 (1.0)
		24 VDC	0.95 (1.0)
Apparent power	VA	100 VAC	2.3 (2.4)
		110 VAC	2.5 (2.6)
Heat proof class		B	
Surge suppressor		Option	
Indicator		With indicator light (option)	

Note 4: The value in () applies when an indicator light is installed.

Flow characteristics

Model no.	Solenoid position		P → A/B		A/B → R1/R2	
			C [dm ³ /(s·bar)]	b	C [dm ³ /(s·bar)]	b
M4GA4	2-position		7.3	0.12	9.0	0.17
	3-position	All ports closed	6.4	0.15	8.2	0.22
		ABR connection	6.4	0.16	9.3	0.19
		PAB connection	8.0	0.08	8.3	0.22

Note 1: Effective sectional area S and sonic conductance C are converted as $S \cong 5.0 \times C$.

Coolant proof specifications

Select with E Option "A" in How to order on page 31.

M4GA4 Series

Individual wiring type manifold; body porting

How to order

Manifold model no.

M **4GA4** **1** **0** - **10** - **E2** **A** - **3** - **3**

Discrete valve for incorporated base

4GA4 **1** **9** - **10** - **E2** **A** - **3**

A Model no.

B Solenoid position

C Port size

D Electric connection

E Option

F Station number

G Voltage

*Complete "Manifold Specifications" (page 66).

A Model no.

4GA4

Symbol	Descriptions	
B Solenoid position		
1	2-position single solenoid	●
2	2-position double solenoid	●
3	3-position all ports closed	●
4	3-position ABR connection	●
5	3-position PAB connection	●
8	Mix manifold	●
C Port size		
Port	A/B port	P/R1/R2 port Rc1/2
C8	ø8 push-in joint	●
C10	ø10 push-in joint	●
C12	ø12 push-in joint	●
CX	Push-in joint mix	●
10	Rc3/8	●
10G	G3/8	● Note 1
10N	NPT3/8	● Note 2
D Electric connection		
Refer to the next page for wire connections.		
E Option		
Blank	None	●
K	External pilot Note 3	●
A	Coolant proof	●
F	A/B port filter integrated	●
Z1	Air supply spacer Note 4	●
Z3	Exhaust spacer Note 4	●
Q	Supply and exhaust block	●
F Station number		
2	2 station	●
to		
15	15 station	
G Voltage		
1	100 VAC (rectified bridge integrated)	●
3	24 VDC	●
4	12 VDC	●
5	110 VAC (rectified bridge integrated)	●

⚠ Note on model no. selection

Note 1: P/R port is G1/2.

Note 2: P/R port is NPT1/2.

Note 3: Consult with CKD when using a vacuum with the external pilot (K).

Note 4: Indicate the spacer installation location and amount with manifold specifications.

Refer to Page 61 to 62 for details.

(Electric connection list)

		A Model no.
		4GA4
D Electric connection		
Blank	Grommet lead wire (300mm)	●
B	DIN terminal box (Pg7) With surge suppressor and indicator light	●
E-connector (radial/axial common)		
E0	Lead wire (300mm)	●
E00	Lead wire (500mm)	●
E01	Lead wire (1000mm)	●
E02	Lead wire (2000mm)	●
E03	Lead wire (3000mm)	●
E2	Lead wire (300mm) With surge suppressor and indicator light	●
E20	Lead wire (500mm) With surge suppressor and indicator light	●
E21	Lead wire (1000mm) With surge suppressor and indicator light	●
E22	Lead wire (2000mm) With surge suppressor and indicator light	●
E23	Lead wire (3000mm) With surge suppressor and indicator light	●
E0N	No lead wire (without socket)	●
E2N	No lead wire (without socket) With surge suppressor and indicator light	●
E3	No lead wire (socket and terminal attached) With surge suppressor and indicator light	●
E1	No lead wire (socket and terminal attached)	●
EJ-connector (socket with cover, up and axial common)		
E01J	Lead wire (1000mm)	●
E02J	Lead wire (2000mm)	●
E03J	Lead wire (3000mm)	●
E21J	Lead wire (1000mm) With surge suppressor and indicator light	●
E22J	Lead wire (2000mm) With surge suppressor and indicator light	●
E23J	Lead wire (3000mm) With surge suppressor and indicator light	●

M4GA4 Series

Individual wiring type manifold; body porting

Manifold components and parts list

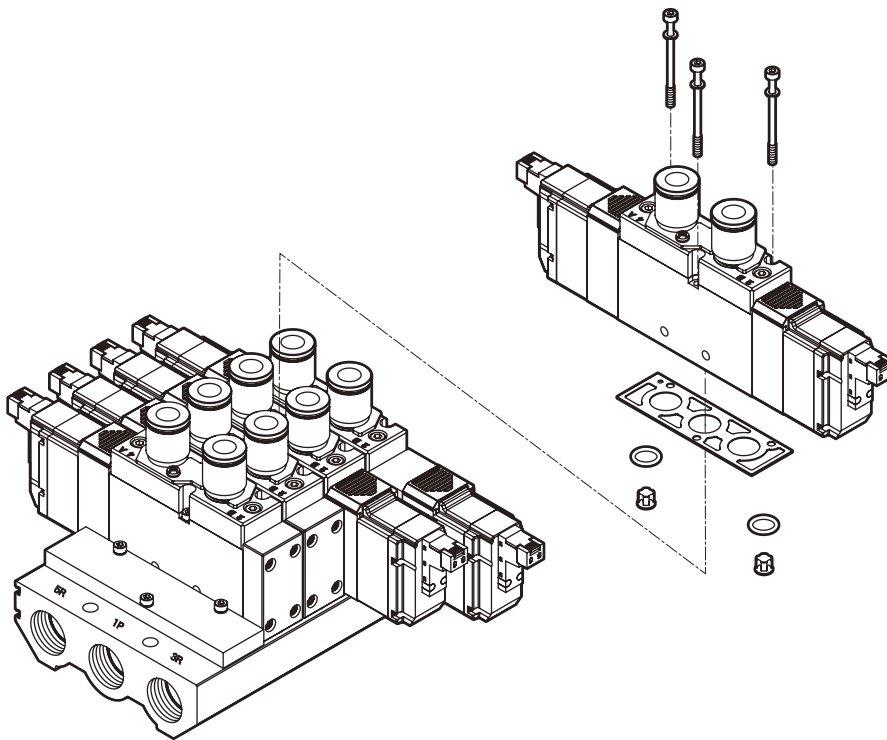

Main parts list

No.	Component name	Model no.	Descriptions	Remarks		
				Size	Tightening torque (N•m)	
1	Discrete valve for incorporated base	4GA4*9- <div style="display: flex; justify-content: space-between; align-items: center;"> <div style="border: 1px solid black; padding: 2px;">Port size</div> <div style="border: 1px solid black; padding: 2px;">Electric connection</div> <div style="border: 1px solid black; padding: 2px;">Option</div> <div style="border: 1px solid black; padding: 2px;">Voltage</div> </div> <div style="margin-left: 20px; margin-top: 10px;"> <div style="border: 1px solid black; padding: 2px;">Solenoid position</div> </div>	Discrete valve Gasket Set screw 3 O ring 2 Quick exhaust valve 2 (1)	4GA4	M3	1.7
2	Masking plate	4GA4-MP	Masking plate Gasket Set screw 3 O ring 2 Quick exhaust valve 2			
3	Manifold base assembly	M4GA4-00- <div style="display: flex; justify-content: space-between; align-items: center;"> <div style="border: 1px solid black; padding: 2px;">Option</div> <div style="border: 1px solid black; padding: 2px;">Station number</div> </div>	Manifold base			

() applies when 4GA419 is selected.

Repair parts and related parts list

No.	Parts name	Model no.	No.	Parts name	Model no.
-	E-connector socket assembly	4G4-SOCKET-ASSY- <div style="border: 1px solid black; padding: 2px;">Electric connection</div> - <div style="border: 1px solid black; padding: 2px;">Voltage</div>	-	Silencer	SLW-15A for Rc1/2
-	EJ-connector socket assembly	4G-SOCKET-ASSY- <div style="border: 1px solid black; padding: 2px;">Electric connection</div>	-	Cartridge type push-in joint and related parts	ø8 axial 4G4-JOINT-C8
			ø10 axial 4G4-JOINT-C10		
			ø12 axial 4G4-JOINT-C12		

MEMO

M4GA4 Series

Individual wiring type manifold; body porting

Dimensions

M4GA4

- Grommet lead wire (blank) DC specifications

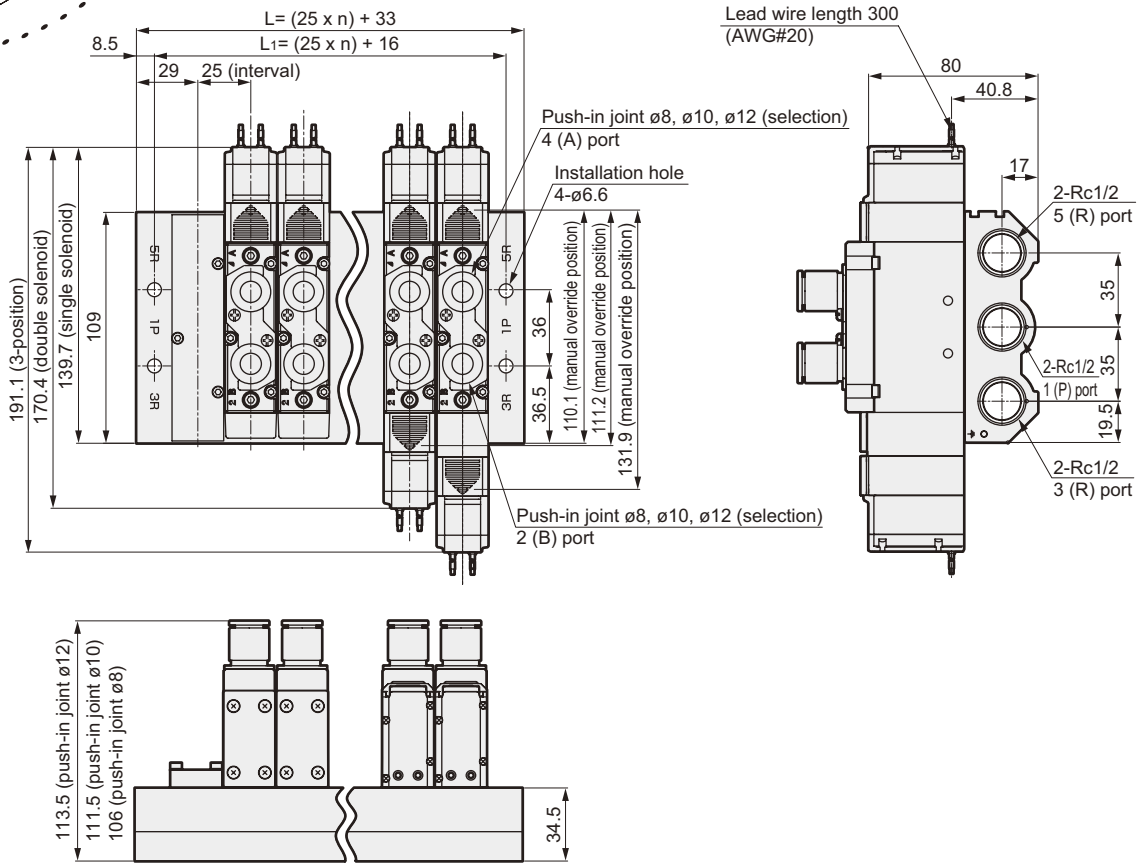
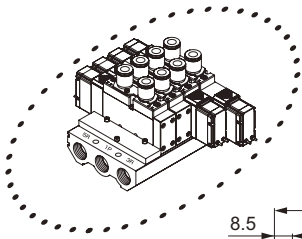

- Rc3/8 female thread type (10)

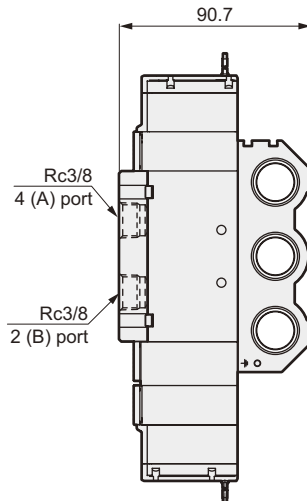
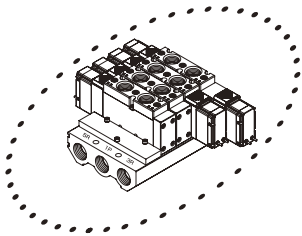

Station number	2	3	4	5	6	7	8	9	10	11	12	13	14	15
L	83	108	133	158	183	208	233	258	283	308	333	358	383	408
L ₁	66	91	116	141	166	191	216	241	266	291	316	341	366	391

Dimensions

● Grommet lead wire (blank) AC specifications

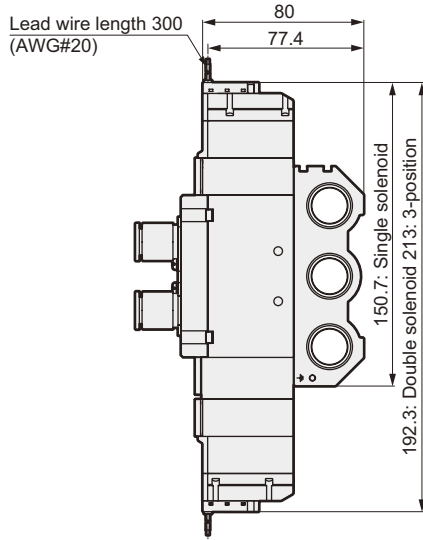

● E-connector type (E)

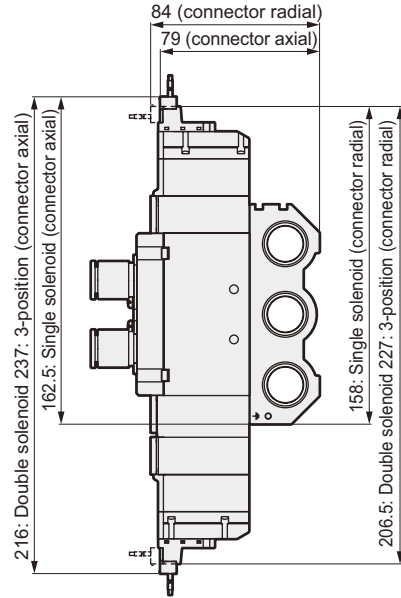

● EJ-connector type (E**J)

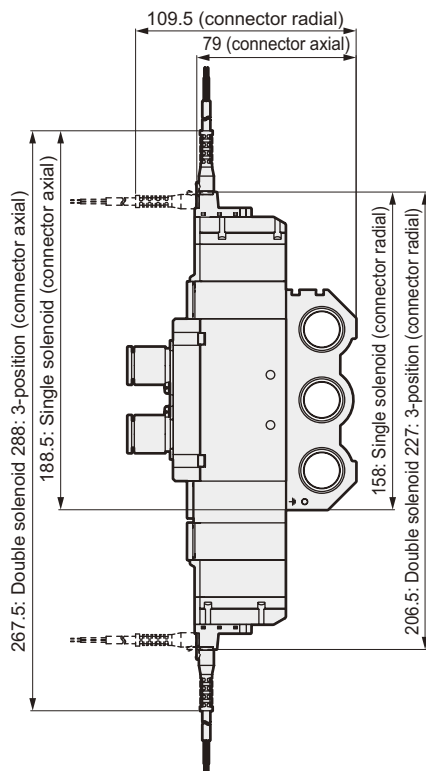

● DIN terminal box type (B)

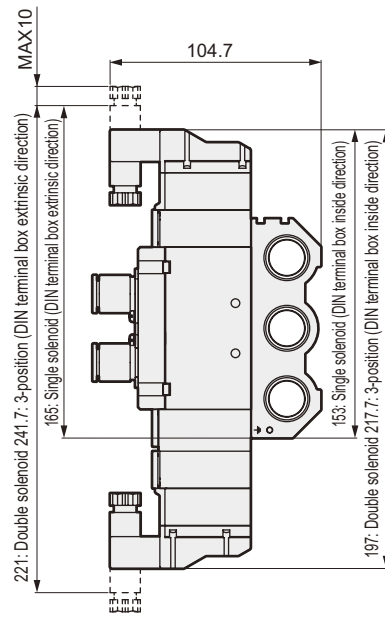

Dimensions

- External pilot (K)
Grommet lead wire (blank) AC specifications

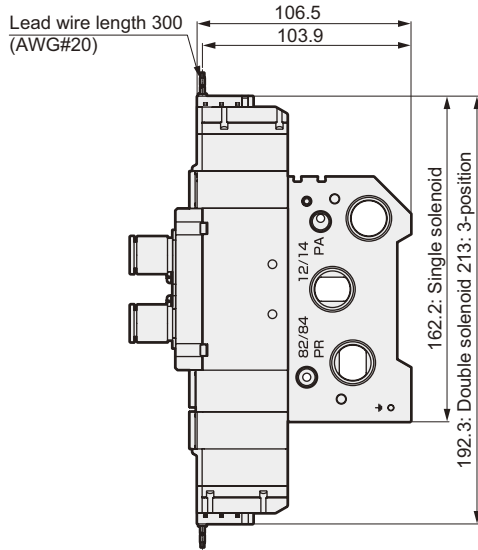

- External pilot (K)
E-connector type (E)

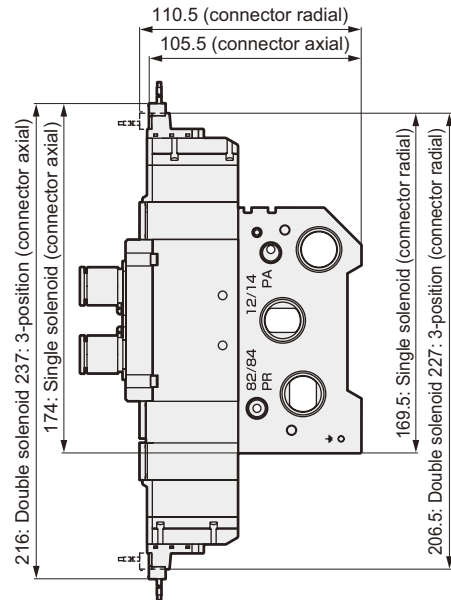

- External pilot (K)
EJ-connector type (E**J)

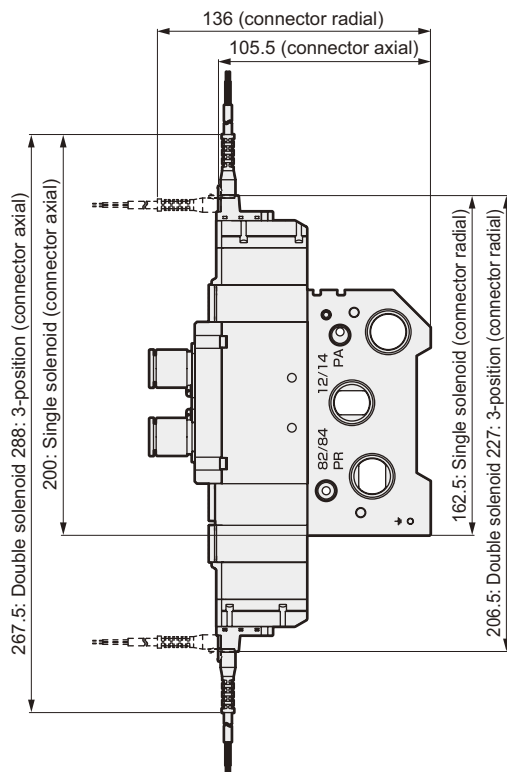

- External pilot (K)
DIN terminal box type (B)

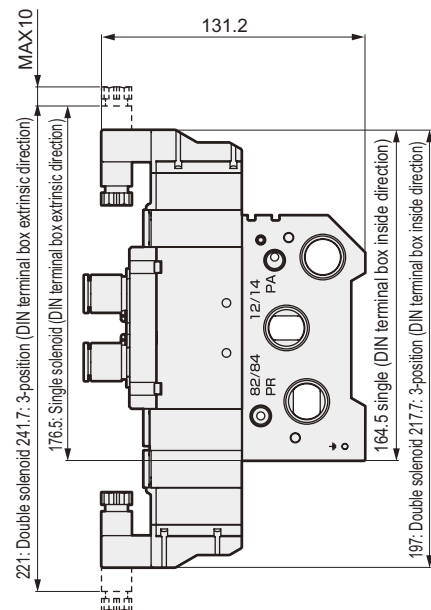

M4GA4 Series

Individual wiring type manifold; body porting

Dimensions

M4GA4

- Supply and exhaust block (Q)
Grommet lead wire (blank) DC specifications

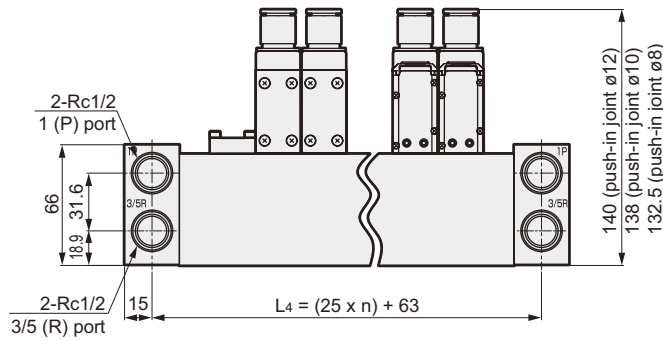
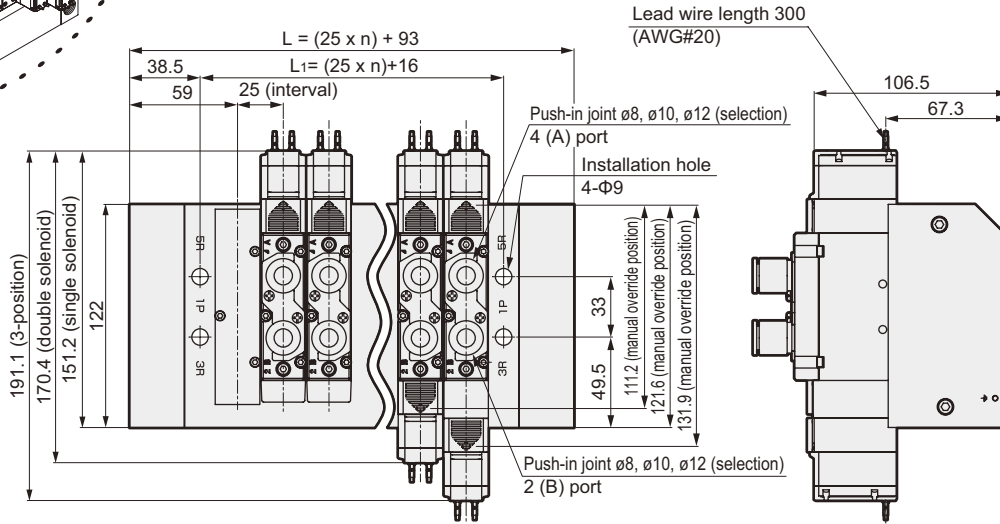
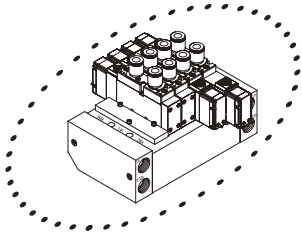

- Supply and exhaust block (Q)
Rc3/8 female thread type (10)

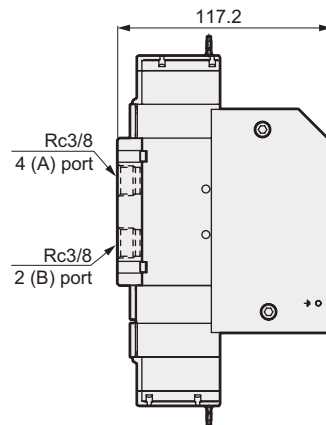
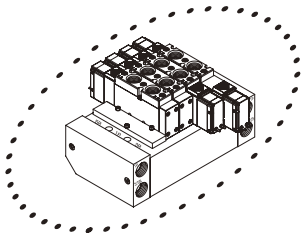

Station number	2	3	4	5	6	7	8	9	10	11	12	13	14	15
L	143	168	193	218	243	268	293	318	343	368	393	418	443	468
L ₁	66	91	116	141	166	191	216	241	266	291	316	341	366	391
L ₄	113	138	163	188	213	238	263	288	313	338	363	388	413	438

Dimensions

- Supply and exhaust block (Q)
Grommet lead wire (blank) AC specifications

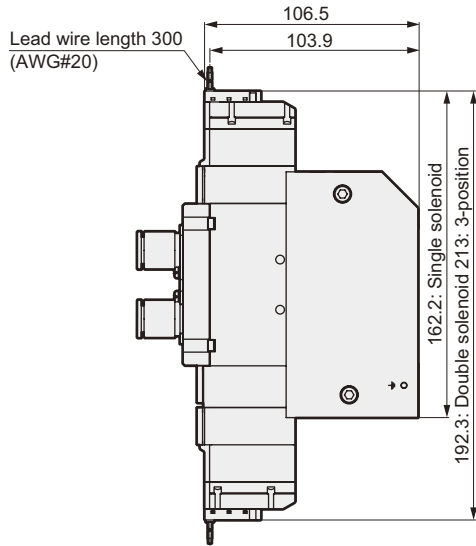

- Supply and exhaust block (Q)
E-connector type (E)

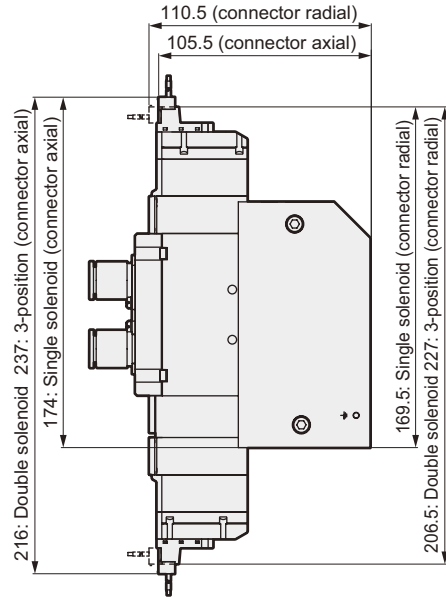

- Supply and exhaust block (Q)
EJ-connector type (E**J)

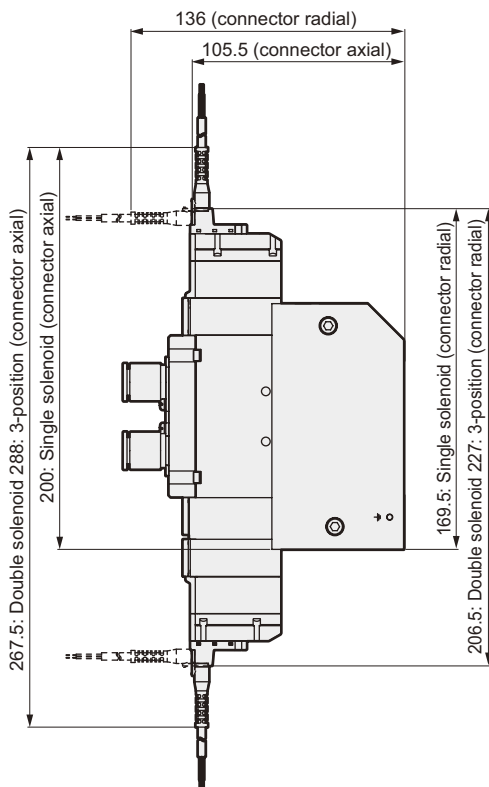

- Supply and exhaust block (Q)
DIN terminal box type (B)

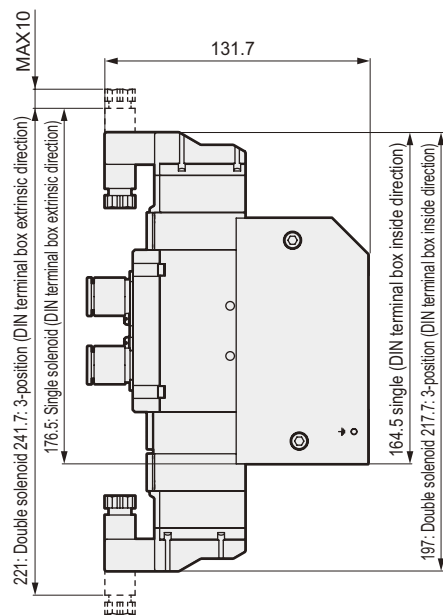

M4GA4 Series

Individual wiring type manifold; body porting

Dimensions

M4GA4

- External pilot (K)
Supply and exhaust block (Q)
Grommet lead wire (blank) AC specifications

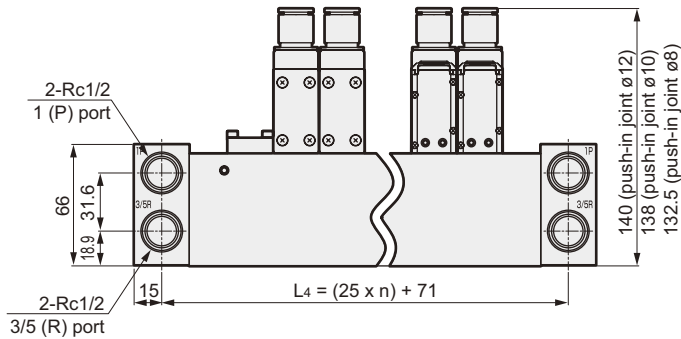
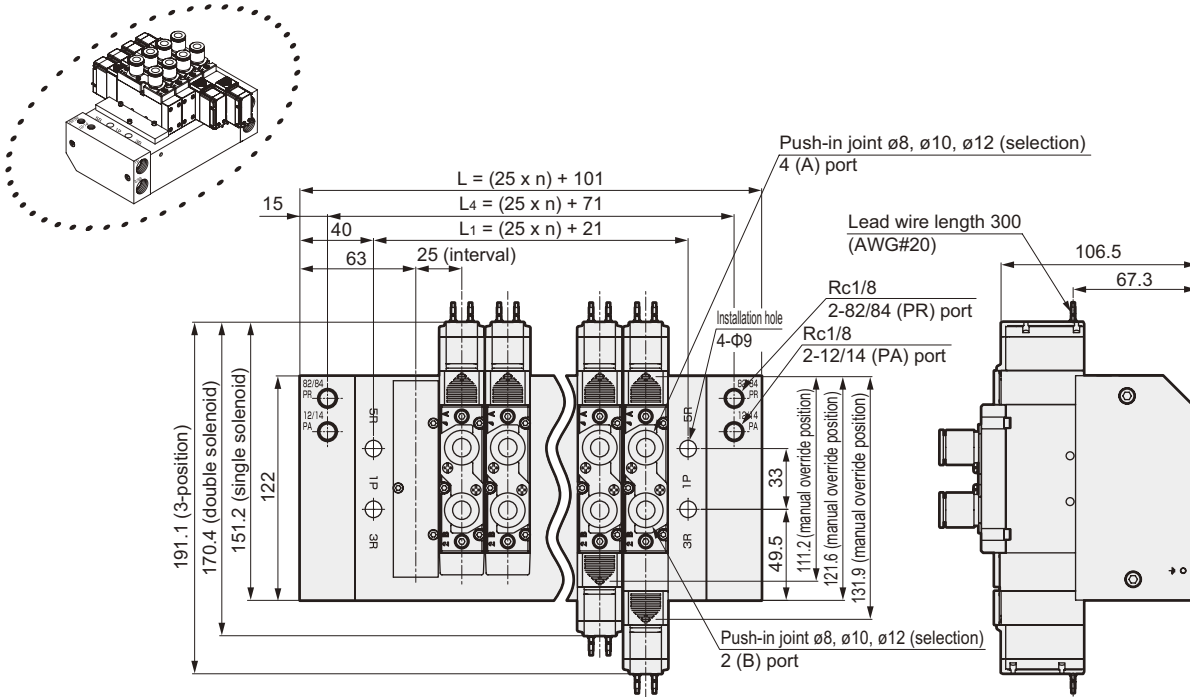

- External pilot (K)
Supply and exhaust block (Q)
Rc female thread type (10)

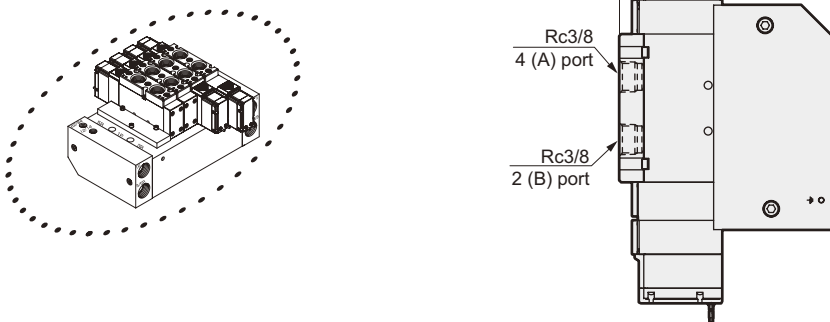

Station number	2	3	4	5	6	7	8	9	10	11	12	13	14	15
L	151	176	201	226	251	276	301	326	351	376	401	426	451	476
L ₁	71	96	121	146	171	196	221	246	271	296	321	346	371	396
L ₄	121	146	171	196	221	246	271	296	321	346	371	396	421	446

Dimensions

- External pilot (K)
Supply and exhaust block (Q)
Grommet lead wire (blank) AC specifications

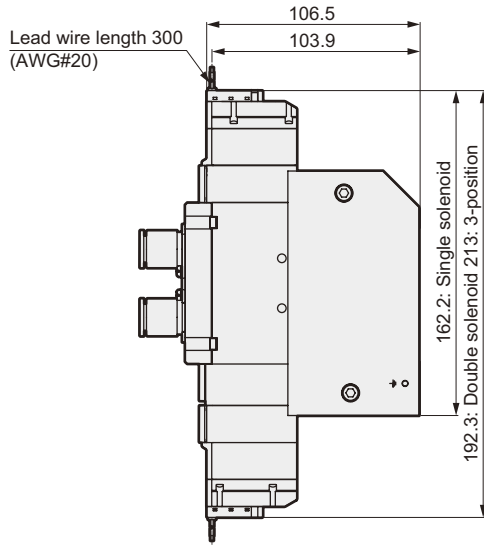

- External pilot (K)
Supply and exhaust block (Q)
E-connector type (E)

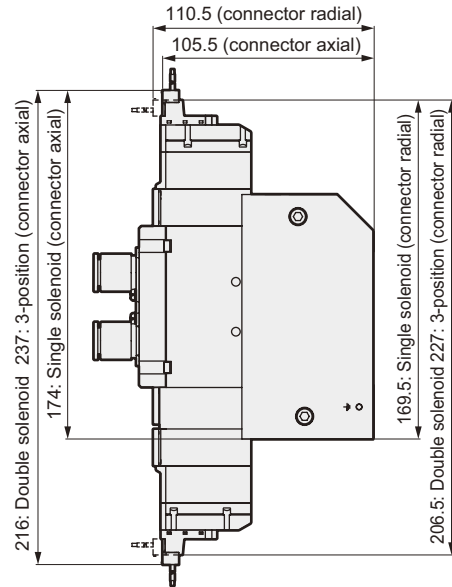

- External pilot (K)
Supply and exhaust block (Q)
EJ-connector type (E**J)

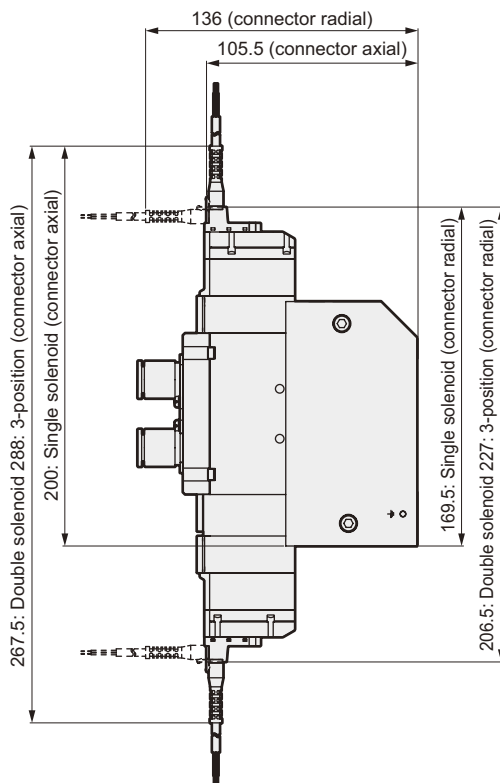

- External pilot (K)
Supply and exhaust block (Q)
DIN terminal box type (B)

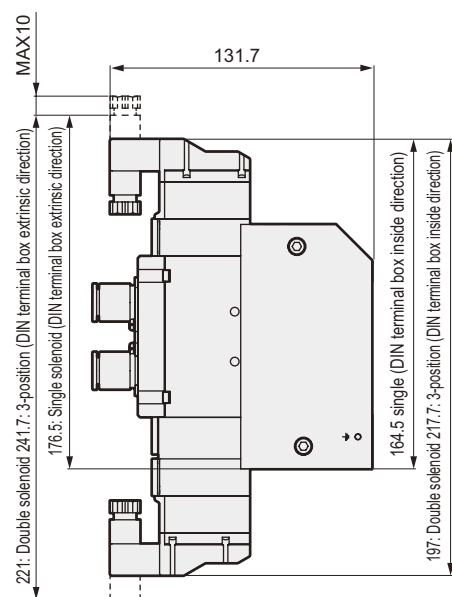

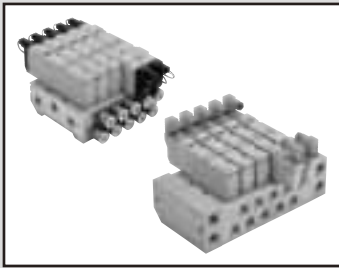

Individual wiring type manifold
Sub-base porting
Direct mount type

M4GB4- (D) Series

● Applicable cylinder bore size: $\varnothing 100$ to $\varnothing 140$

Common manifold specifications

Descriptions		
Manifold type		Integrated base
How to install the product		Direct mount type
Air supply and exhaust method		Common supply and common exhaust
Pilot exhaust method	Internal pilot	Main valve and pilot valve common exhaust (Pilot exhaust check valve integrated)
	External pilot	Main valve and pilot valve individual exhaust
Piping direction		Sub-base side porting
Type of valve and operator type		Pilot operated soft spool valve
Working fluid		Compressed air
Max. working pressure	MPa	0.7
Min. working pressure	MPa	0.2 (2-position, 3-position)
Withstanding pressure	MPa	1.05
Ambient temperature	°C	-5 to 55 (no freezing)
Fluid temperature	°C	5 to 55
Manual override		Non-locking/locking common type
Lubrication	Note 1	Not required
Protective structure	Note 2	Dust proof
Vibration/shock	m/s ²	50 or less/300 or less
Working environment		Use in the environment containing corrosive gas is not permissible.

Note 1: Use the turbine oil Class 1 1SOVG32 if lubricated. Excessive or intermittent lubrication results in instable operation.

Note 2: Check that water drops or oil, etc., do not come into contact.

IP65 (jet-proof type) is used for DIN terminal box specifications. Note that the box must be fixed using the specified adaptive cord outer diameter and tightening torque.

Note 3: External pilot pressure when the external pilot (option symbol: K) is selected must be within the minimum/maximum working pressure range of the individual model. Note that it must be higher than the main valve working pressure.

JIS symbol

● 5 port valve

2-position single solenoid

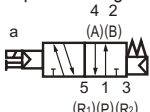

2-position double solenoid

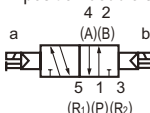

3-position

all ports closed

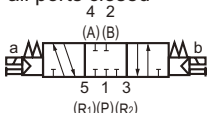

3-position A/B/R connection

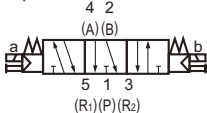

3-position P/A/B connection

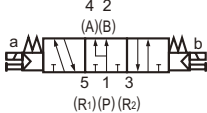

Individual specifications

Descriptions		M4GB4		
		Direct mount		DIN rail mount Note 4
Pilot operated		Standard (internal pilot)		External pilot Note 3
Maximum station number		15 station	12 station	
Port size	A/B port	Push-in joint $\varnothing 8, \varnothing 10, \varnothing 12$ Rc1/4, Rc3/8 G1/4, G3/8 NPT1/4, NPT3/8	Rc1/2, G1/2, NPT1/2	Push-in joint $\varnothing 8, \varnothing 10, \varnothing 12$ Rc1/4, Rc3/8, Rc1/2 G1/4, G3/8, G1/2 NPT1/4, NPT3/8, NPT1/2
	P/R1/R2 port	Rc3/8, G3/8, NPT3/8, Note 1	Rc1/2, G1/2, NPT1/2	Note 2 Rc3/8, G3/8, NPT3/8
Manifold base		273n + 329	391n + 560	392n + 555
Weight calculation formula (n: Number of stations) g				278n + 1082

Refer to the "Precautions for DIN rail installation" (introduction, page 9) and select accordingly.

If there are more than five manifold stations, supply and exhaust from ports on both sides.

The manifold base weight is the value for screw specifications.

Port size (P/R1/R2 port) dimensions differ in Rc3/8 and Rc1/2.

Note 1: Refer to Page 49 to 50, 55 to 56 for dimensions of port size Rc3/8.

Note 2: Refer to Page 51 to 52, 57 to 58 for dimensions of port size Rc1/2.

Note 3: Refer to Page 53 to 54, 59 to 60 for dimensions of external pilot (option symbol: K).

Note 4: Refer to Page 55 to 56 for dimensions of DIN rail mount (option symbol: D).

Electric specifications

Descriptions		
Rated voltage	V DC	12, 24
	AC	100, 110
Rated voltage fluctuation range		$\pm 10\%$
Holding current	12 VDC	0.079 (0.083)
	24 VDC	0.040 (0.042)
Note 4	A 100 VAC	0.023 (0.024)
	110 VAC	0.023 (0.024)
Power consumption	W 12 VDC	0.95 (1.0)
	24 VDC	0.95 (1.0)
Apparent power	VA 100 VAC	2.3 (2.4)
	110 VAC	2.5 (2.6)
Heat proof class		B
Surge suppressor		Option
Indicator		With indicator light (option)

Note 4: The value in () applies when an indicator light is installed.

Vibration/Impact

Keep vibration at 30 m/s² or less and impact at 150 m/s² or less when using the DIN rail.

Flow characteristics

Model no.	Port size P, R1, R2	Solenoid position		P → A/B		A/B → R1/R2	
				C [dm ³ /(s•bar)]	b	C [dm ³ /(s•bar)]	b
M4GB4	Note 1 Rc3/8 G3/8 NPT3/8	2-position		6.4	0.42	6.9	0.12
		3-position	All ports closed	6.0	0.37	6.8	0.12
			ABR connection	6.1	0.38	7.1	0.15
			PAB connection	6.0	0.37	6.8	0.13
	Note 2 Rc1/2 G1/2 NPT1/2	2-position		8.3	0.23	9.0	0.21
		3-position	All ports closed	7.4	0.15	8.8	0.19
			ABR connection	7.5	0.15	9.5	0.21
			PAB connection	7.7	0.21	8.7	0.18

Port size (P/R1/R2 port) dimensions differ in Rc3/8 and Rc1/2.

Note 1: Refer to Page 49 to 50, 55 to 56 for dimensions of port size Rc3/8.

Note 2: Refer to Page 51 to 52, 57 to 58 for dimensions of port size Rc1/2.

Note 3: Effective sectional area S and sonic conductance C are converted as $S \cong 5.0 \times C$.

Coolant proof specifications

Select with E Option "A" in How to order on page 45.

M4GB4 Series

Individual wiring type manifold; sub-base porting

How to order

Manifold model no.

M **4GB4** **1** **0** - **10** - **E2** **A** **D** - **3** - **3**

Discrete valve for incorporated base

4GB4 **1** **9** - **00** - **E2** **A** - **3**

A Model no.

B Solenoid position

C Port size

D Electric connection

E Option

F Mount type

G Station number

*Complete "Manifold Specifications" (page 66).

A Model no.

4GB4

Symbol	Descriptions	
B Solenoid position		
1	2-position single solenoid	●
2	2-position double solenoid	●
3	3-position all ports closed	●
4	3-position ABR connection	●
5	3-position PAB connection	●
8	Mix manifold	●

C Port size		P/R1/R2 port Note 6		
Port	A/B port	Option: Other than K		Option: K
		Rc3/8 Note 7	Rc1/2 Note 8	Rc1/2 Note 9
C8	ø8 push-in joint	●		●
C10	ø10 push-in joint	●		●
C12	ø15 push-in joint	●		●
CX	Push-in joint mix	●		●
08	Rc1/4	●		●
10	Rc3/8	●		●
15	Rc1/2		●	●
08G	G1/4	●Note 1		●Note 1
10G	G3/8	●Note 1		●Note 1
15G	G1/2		●Note 1	●Note 1
08N	NPT1/4	●Note 2		●Note 2
10N	NPT3/8	●Note 2		●Note 2
15N	NPT1/2		●Note 2	●Note 2

D Electric connection
Refer to the next page for wire connections.

E Option		
Blank	None	●
K	External pilot Note 3, 9	●
A	Coolant proof	●
F	A/B port filter integrated	●
Z1	Air supply spacer Note 4	●
Z3	Exhaust spacer Note 4	●
Q	Supply and exhaust block	●

F Mount type		
Blank	Direct mount	●
D	DIN rail mount type Note 5, 10	●

G Station number		
2	2 stations	●
to		
15	Refer to Page 43 for the maximum station number per port size.	

H Voltage		
1	100 VAC (rectified bridge integrated)	●
3	24 VDC	●
4	12 VDC	●
5	110 VAC (rectified bridge integrated)	●

■ Indicates "not available".

⚠ Note on model no. selection

Note 1: P/R port is G thread.

Note 2: P/R port is NPT thread.

Note 3: Consult with CKD when using a vacuum with the external pilot (K).

Note 4: Indicate the spacer installation location and amount with manifold specifications. Refer to Pages 61 and 62 for the details.

Note 5: DIN rail installation is used only for the P/R port size Rc3/8 base and not for the external pilot. Select the air supply/exhaust block for DIN rail installation. Maximum station number is 5.

Note 6: 2 types of base are available. Dimensions of P/R1/R2 port differ per port size.

Note 7: Refer to Page 49 to 50, 55 to 56 for dimensions of port size Rc3/8.

Note 8: Refer to Page 51 to 52, 57 to 58 for dimensions of port size Rc1/2.

Note 9: Refer to Page 53 to 54, 59 to 60 for dimensions of external pilot (option symbol: K).

Note 10: Refer to Page 55 to 56 for dimensions of DIN rail mount (option symbol: D).

(Electric connection list)

		A Model no.
		4GB4
D Electric connection		
Blank	Grommet lead wire (300mm)	●
B	DIN terminal box (Pg7) With surge suppressor and indicator light	●
E-connector (radial/axial common)		
E0	Lead wire (300mm)	●
E00	Lead wire (500mm)	●
E01	Lead wire (1000mm)	●
E02	Lead wire (2000mm)	●
E03	Lead wire (3000mm)	●
E2	Lead wire (300mm) With surge suppressor and indicator light	●
E20	Lead wire (500mm) With surge suppressor and indicator light	●
E21	Lead wire (1000mm) With surge suppressor and indicator light	●
E22	Lead wire (2000mm) With surge suppressor and indicator light	●
E23	Lead wire (3000mm) With surge suppressor and indicator light	●
E0N	No lead wire (without socket)	●
E2N	No lead wire (without socket) With surge suppressor and indicator light	●
E3	No lead wire (socket and terminal attached) With surge suppressor and indicator light	●
E1	No lead wire (socket and terminal attached)	●
EJ-connector (socket with cover, up and axial common)		
E01J	Lead wire (1000mm)	●
E02J	Lead wire (2000mm)	●
E03J	Lead wire (3000mm)	●
E21J	Lead wire (1000mm) With surge suppressor and indicator light	●
E22J	Lead wire (2000mm) With surge suppressor and indicator light	●
E23J	Lead wire (3000mm) With surge suppressor and indicator light	●

M4GB4 Series

Individual wiring type manifold; body porting

Manifold components explanation and parts list

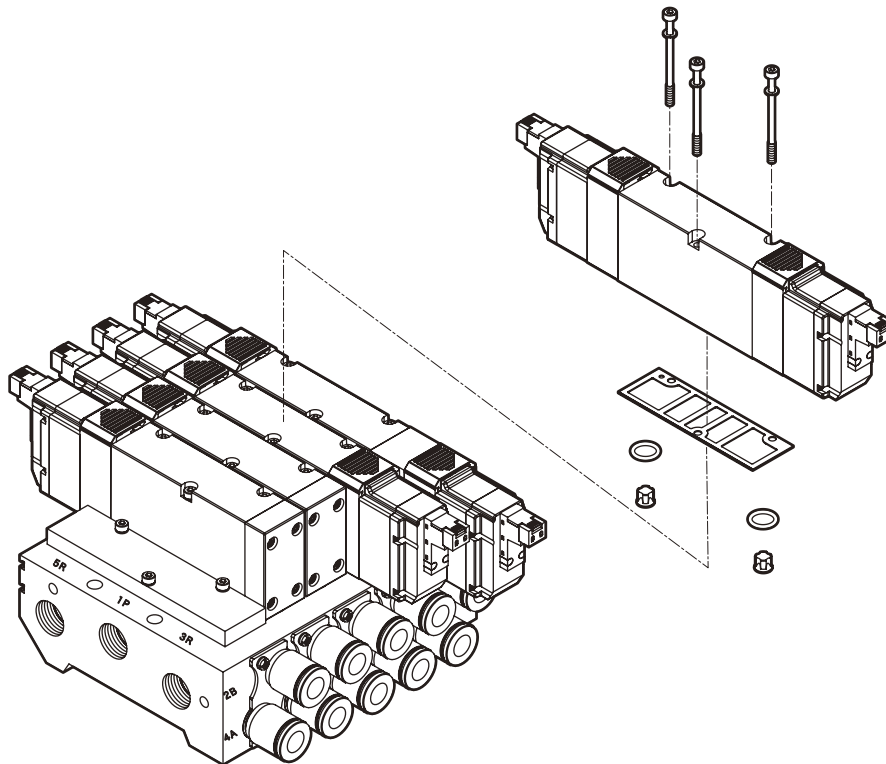

Main parts list

No.	Component name	Model no.	Descriptions	Remarks		
				Size	Tightening torque (N•m)	
1	Discrete valve for incorporated base	4GB4*9-00- Electric connection Option Voltage Solenoid position	Discrete valve Gasket Set screw 3 O ring 2 Quick exhaust valve 2 (1)	4GB4	M3	1.7
2	Masking plate	4GB4-MP	Masking plate Gasket Set screw 3 O ring 2 Quick exhaust valve 2			
3	Manifold base assembly	M4GB4- Port size Option D Station number Mount type	Manifold base			

() applies when 4GB419 is selected.

Repair parts and related parts list

No.	Parts name	Model no.	No.	Parts name	Model no.
-	E-connector socket assembly	4G4-SOCKET-ASSY- Electric connection Voltage	-	Silencer	SLW-15A for Rc1/2 SLW-10A, SLW-10L for Rc3/8
-	EJ-connector socket assembly	4G-SOCKET-ASSY- Electric connection	-	Cartridge type push-in joint and related parts	ø6 axial 4G4-JOINT-C8
			ø8 axial 4G4-JOINT-C10		
			ø10 axial 4G4-JOINT-C12		

MEMO

M4GB4 Series

Individual wiring type manifold; sub-base porting

Dimensions

M4GB4

- Grommet lead wire (blank) DC specifications

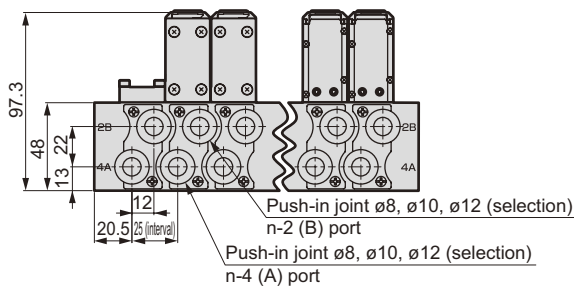
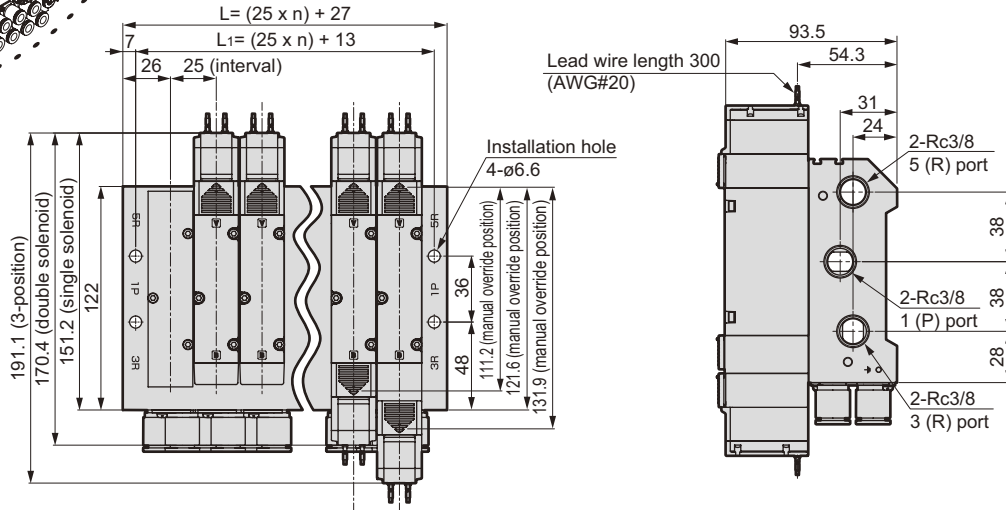
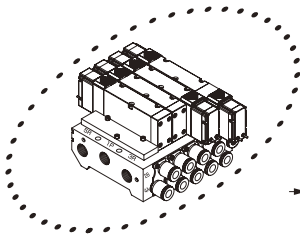

- Rc1/4, Rc3/8 female thread type (08, 10)

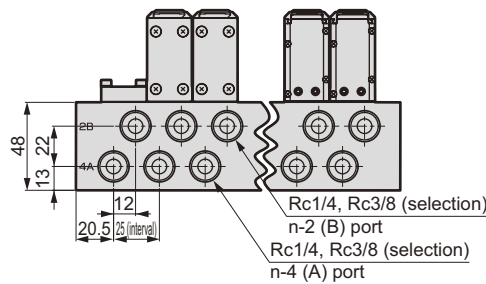
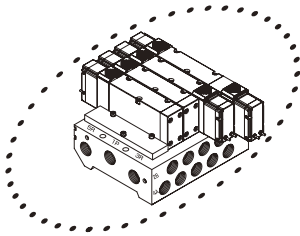

Station number	2	3	4	5	6	7	8	9	10	11	12	13	14	15
L	77	102	127	152	177	202	227	252	277	302	327	352	377	402
L ₁	63	88	113	138	163	188	213	238	263	288	313	338	363	388

Dimensions

● Grommet lead wire (blank) AC specifications

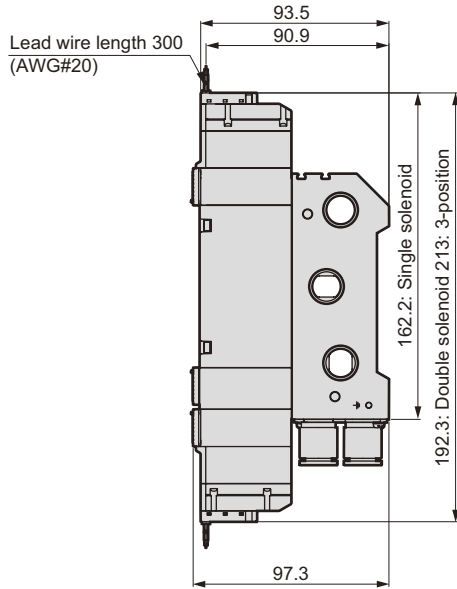

● E-connector type (E)

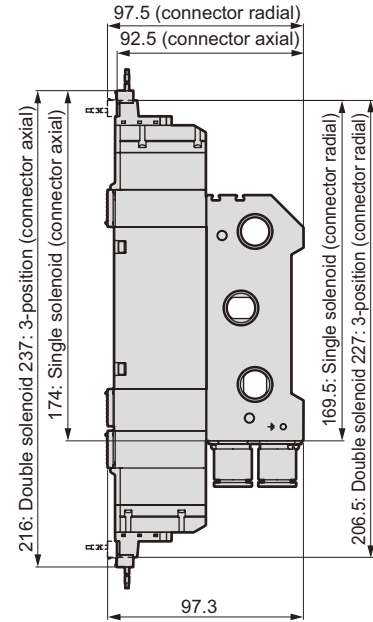

● EJ-connector type (E**J)

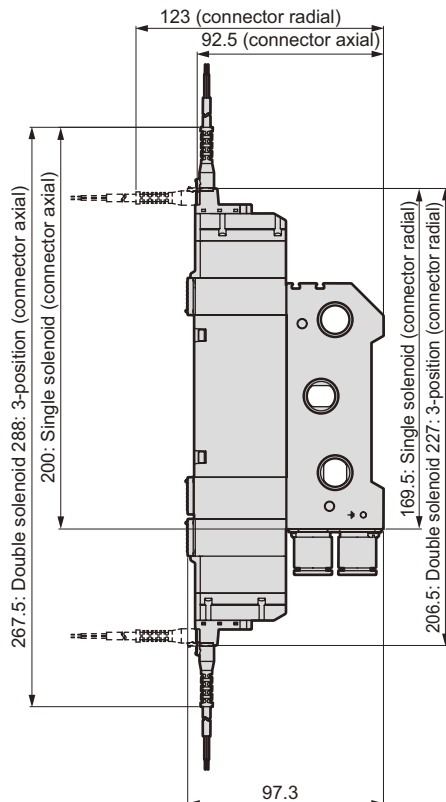

● DIN terminal box type (B)

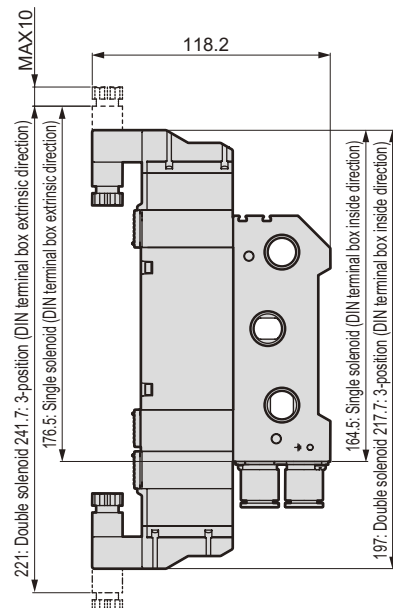

M4GB4 Series

Individual wiring type manifold; sub-base porting

Dimensions

M4GB4

- Rc1/2 female thread type (15)
Grommet lead wire (blank) DC specifications

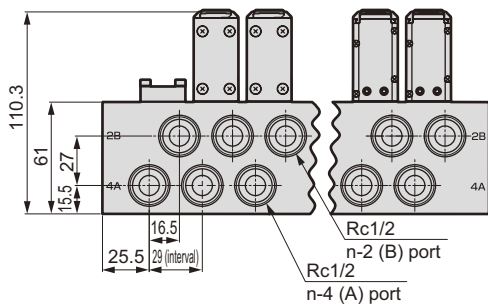
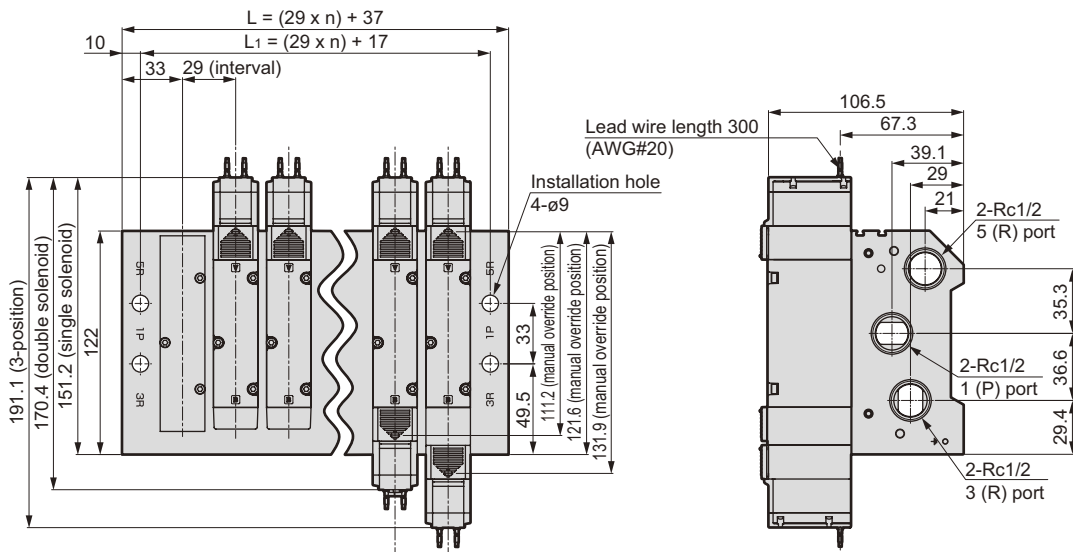
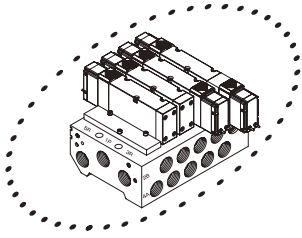

Station number	2	3	4	5	6	7	8	9	10	11	12
L	95	124	153	182	211	240	269	298	327	356	385
L ₁	75	104	133	162	191	220	249	278	307	336	365

Dimensions

- Rc1/2 female thread type (15)
Grommet lead wire (blank) AC specifications

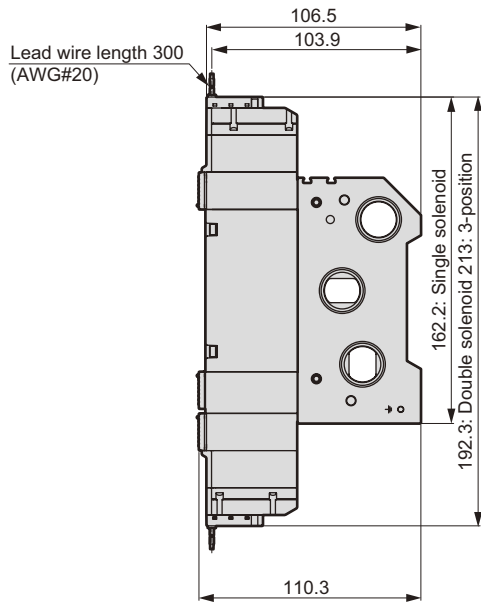

- Rc1/2 female thread type (15)
E-connector type (E)

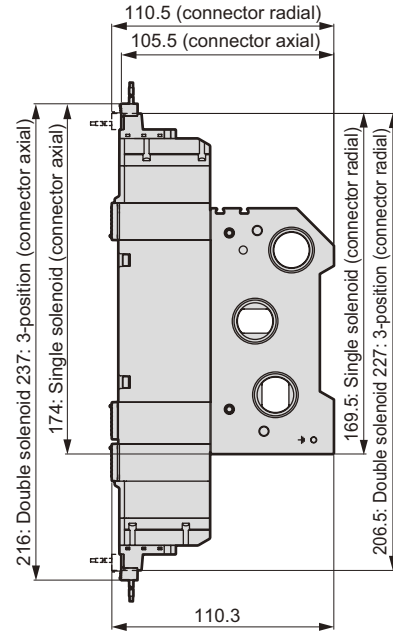

- Rc1/2 female thread type (15)
EJ-connector type (E**J)

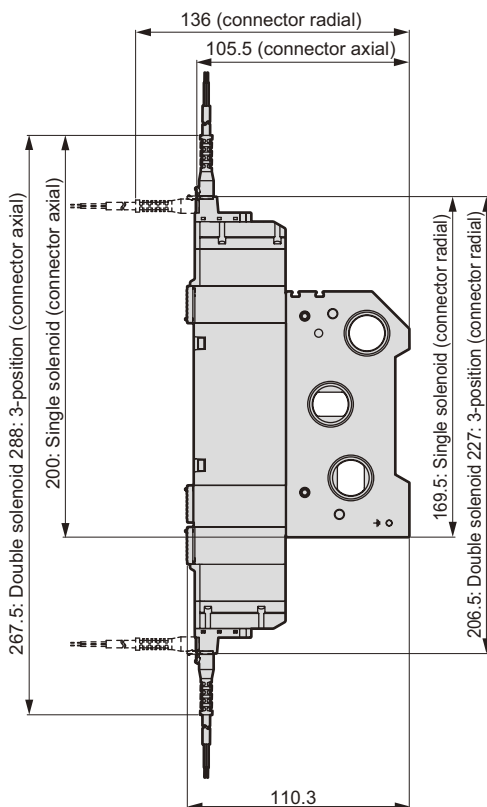

- Rc1/2 female thread type (15)
DIN terminal box type (B)

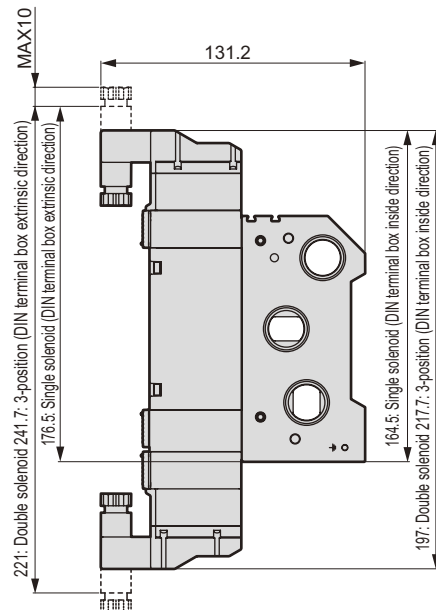

M4GB4 Series

Individual wiring type manifold; sub-base porting

Dimensions

M4GB4

- External pilot (K)
Grommet lead wire (blank) DC specifications

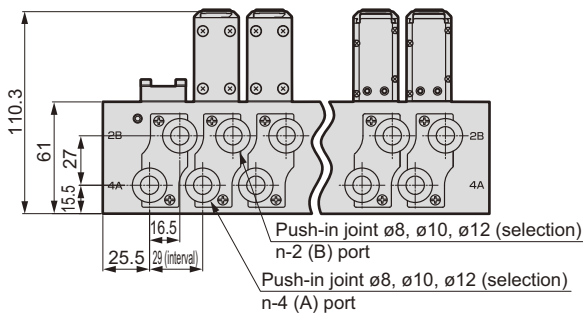
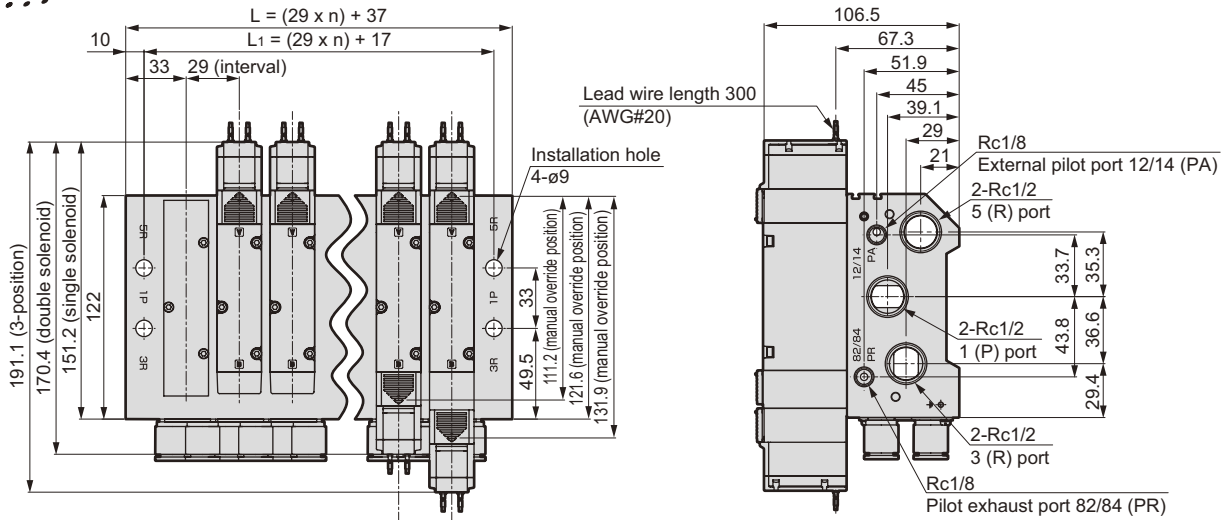
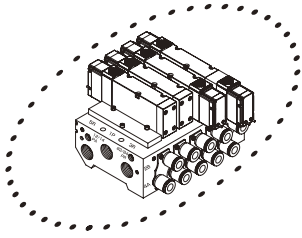

- External pilot (K)
Rc1/4, Rc3/8, Rc1/2 female thread type (08, 10, 15)

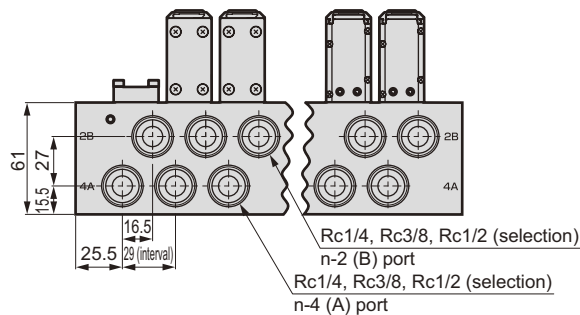
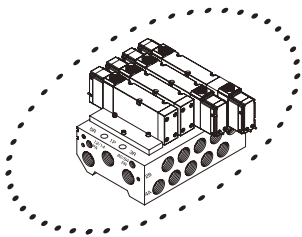

Station number	2	3	4	5	6	7	8	9	10	11	12
L	95	124	153	182	211	240	269	298	327	356	385
L ₁	75	104	133	162	191	220	249	278	307	336	365

Dimensions

- External pilot (K)
Grommet lead wire (blank) AC specifications

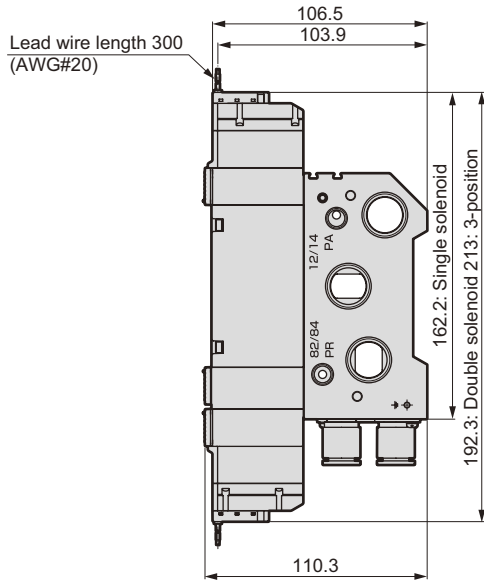

- External pilot (K)
E-connector type (E)

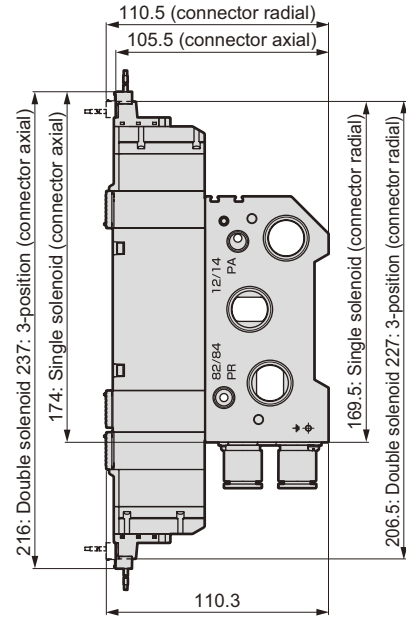

- External pilot (K)
EJ-connector type (E**J)

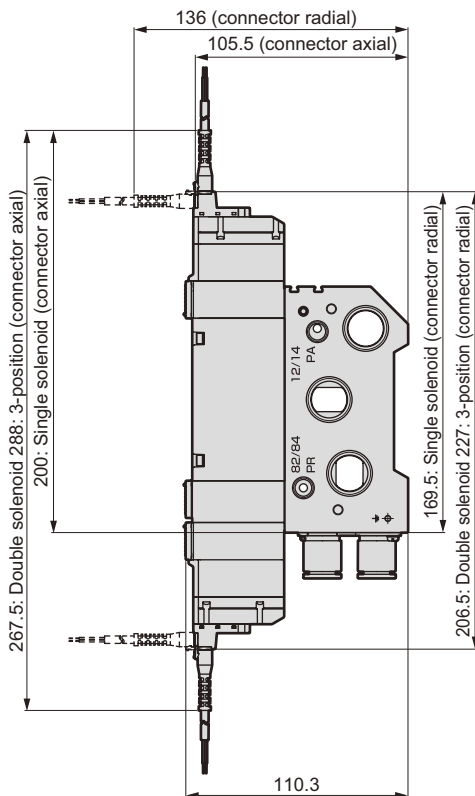

- External pilot (K)
DIN terminal box type (B)

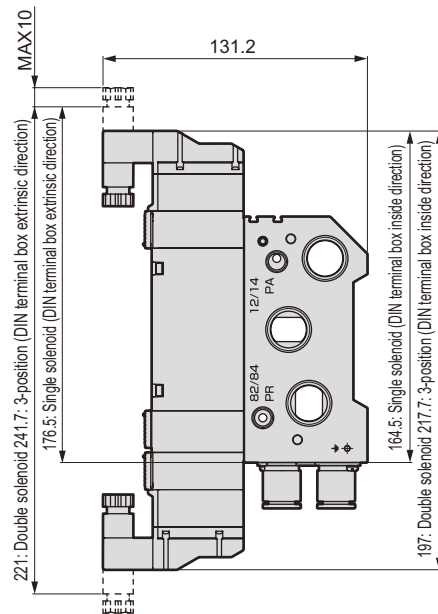

M4GB4 Series

Individual wiring type manifold; sub-base porting

Dimensions

M4GB4

- Supply and exhaust block (Q)
Grommet lead wire (blank) DC specifications

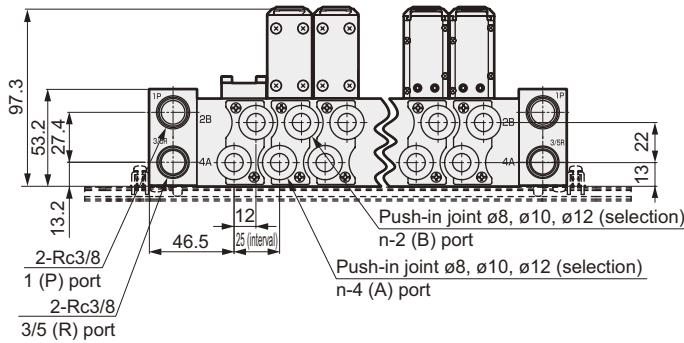
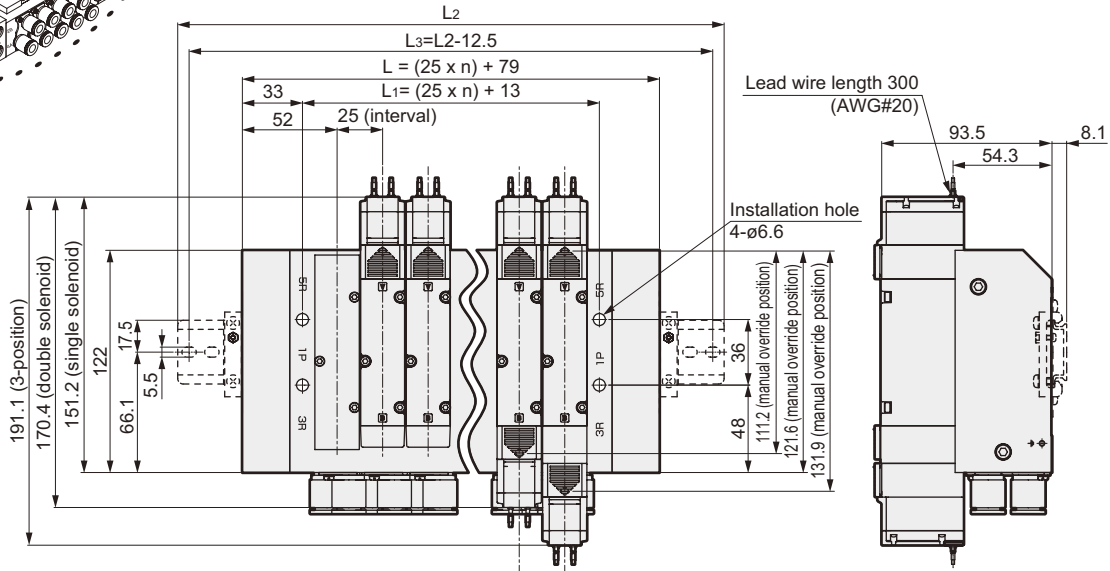
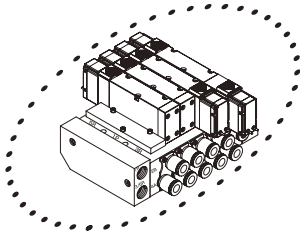

- Supply and exhaust block (Q)
Rc1/4, Rc3/8 female thread type (08, 10)

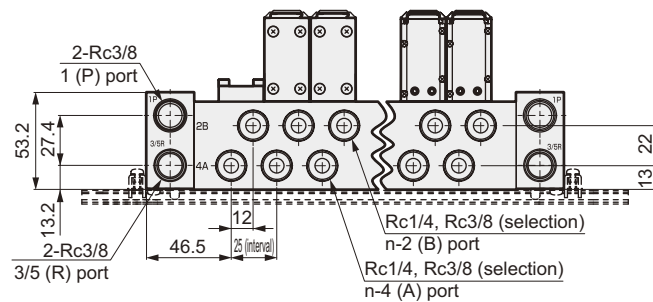
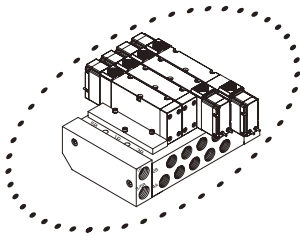

Station number	2	3	4	5	6	7	8	9	10	11	12	13	14	15
L	129	154	179	204	229	254	279	304	329	354	379	404	429	454
L ₁	63	88	113	138	163	188	213	238	263	288	313	338	363	388
L ₂	200	225	250	275										
L ₃	187.5	212.5	237.5	262.5										

Dimensions

- Supply and exhaust block (Q)
Grommet lead wire (blank) AC specifications

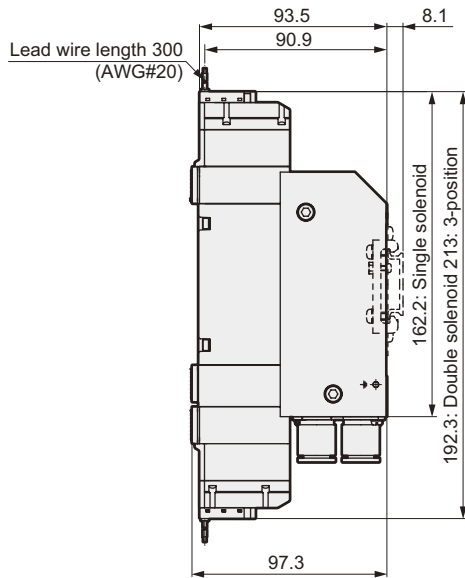

- Supply and exhaust block (Q)
E-connector type (E)

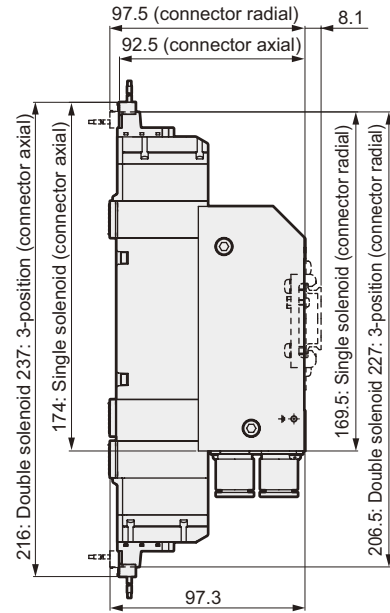

- Supply and exhaust block (Q)
EJ-connector type (E**J)

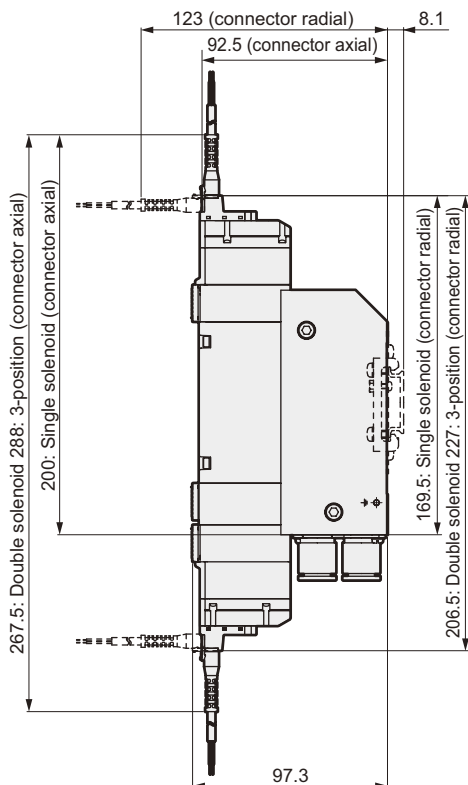

- Supply and exhaust block (Q)
DIN terminal box type (B)

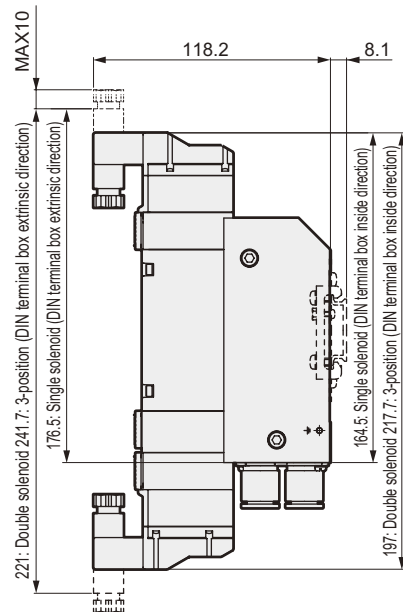

M4GB4 Series

Individual wiring type manifold; sub-base porting

Dimensions

- Supply and exhaust block (Q)
Rc1/2 female thread type (15)
Grommet lead wire (blank) DC specifications

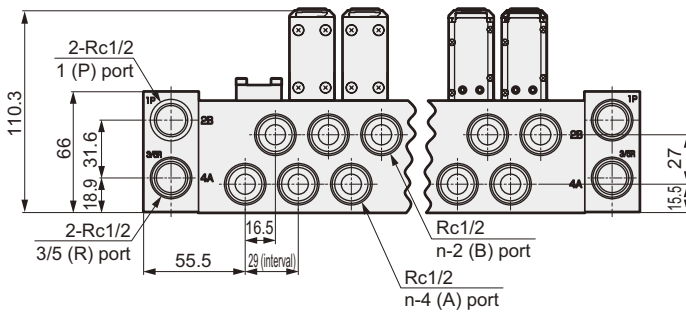
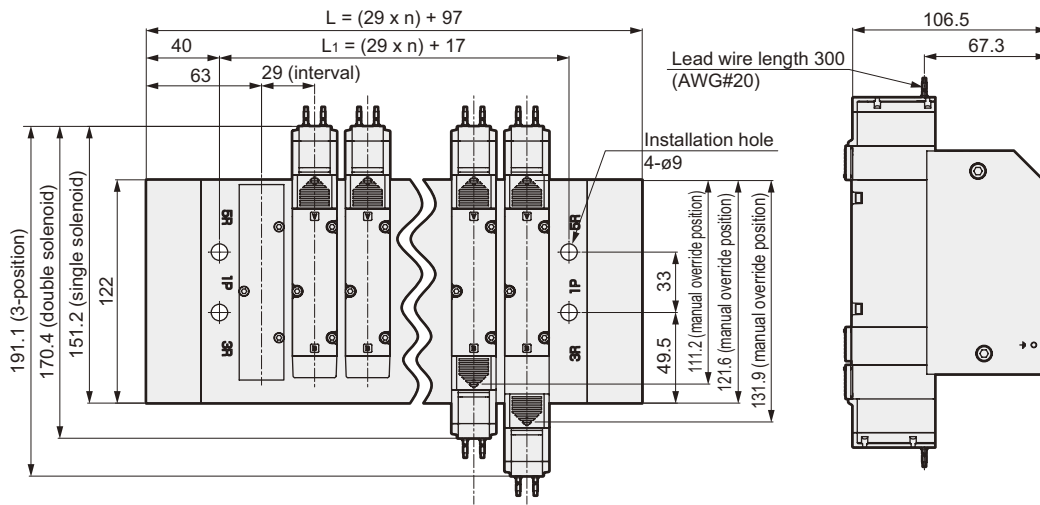
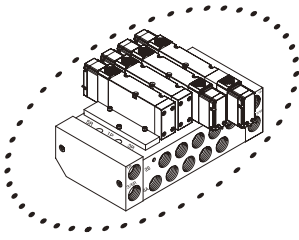

Station number	2	3	4	5	6	7	8	9	10	11	12
L	155	184	213	242	271	300	329	358	387	416	445
L ₁	75	104	133	162	191	220	249	278	307	336	365

Dimensions

- Supply and exhaust block (Q)
Rc1/2 female thread type (15)
Grommet lead wire (blank) AC specifications

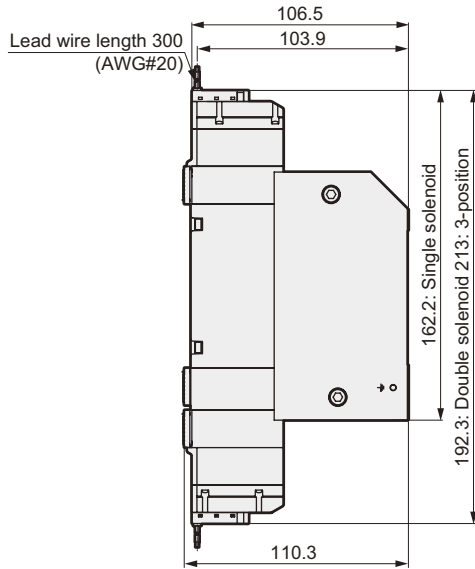

- Supply and exhaust block (Q)
Rc1/2 female thread type (15)
E-connector type (E)

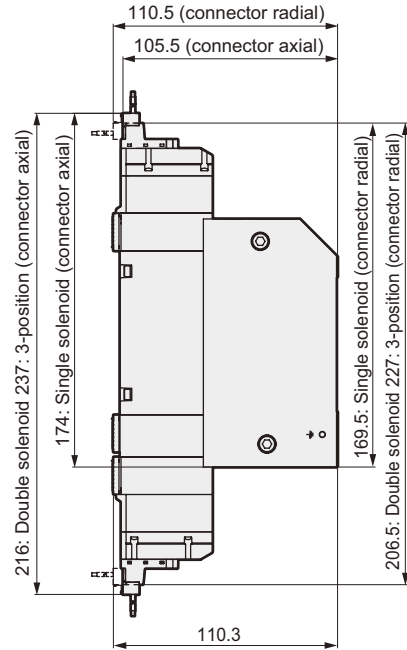

- Supply and exhaust block (Q)
Rc1/2 female thread type (15)
EJ-connector type (E**J)

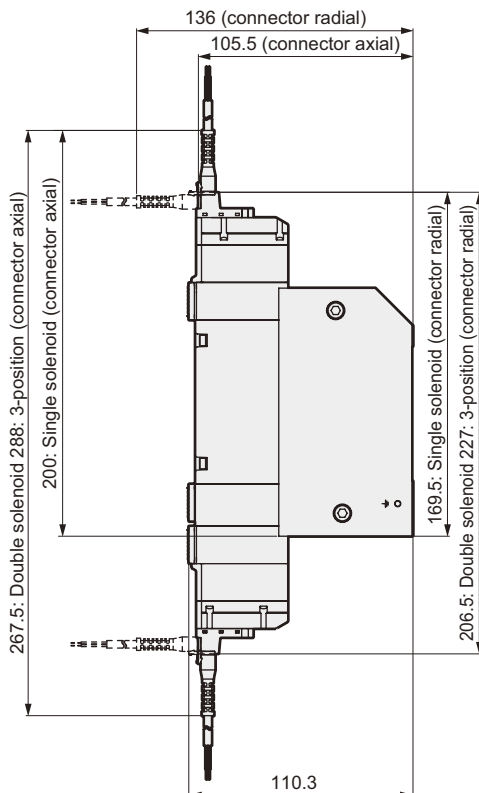

- Supply and exhaust block (Q)
Rc1/2 female thread type (15)
DIN terminal box type (B)

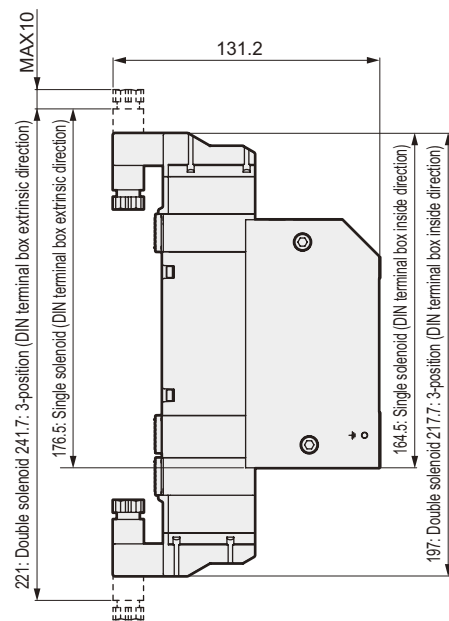

M4GB4 Series

Individual wiring type manifold; sub-base porting

Dimensions

- External pilot (K)
- Supply and exhaust block (Q)
- Grommet lead wire (blank) DC specifications

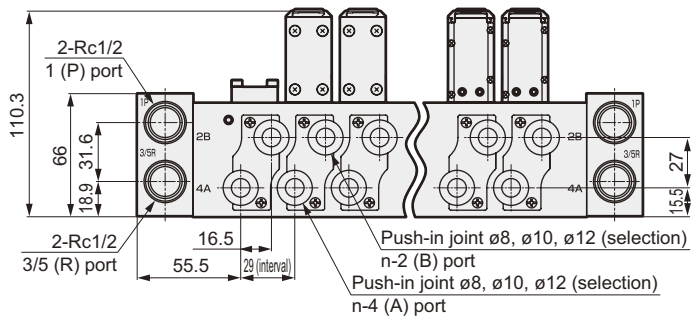
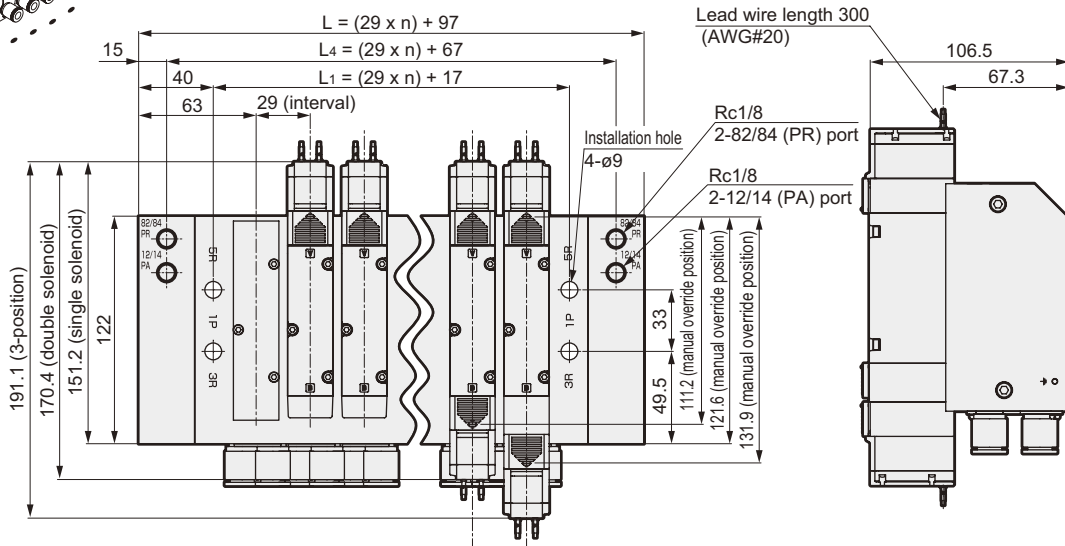
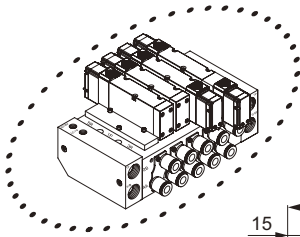

- External pilot (K)
- Supply and exhaust block (Q)
- Rc1/4, Rc3/8, Rc1/2 female thread type (08, 10, 15)

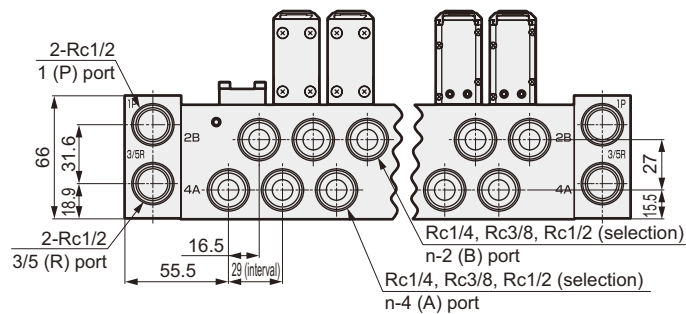
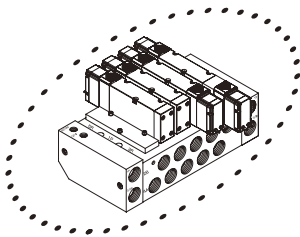

Station number	2	3	4	5	6	7	8	9	10	11	12
L	155	184	213	242	271	300	329	358	387	416	445
L ₁	75	104	133	162	191	220	249	278	307	336	365
L ₄	125	154	183	212	241	270	299	328	357	386	415

Dimensions

- External pilot (K)
Supply and exhaust block (Q)
Grommet lead wire (blank) AC specifications

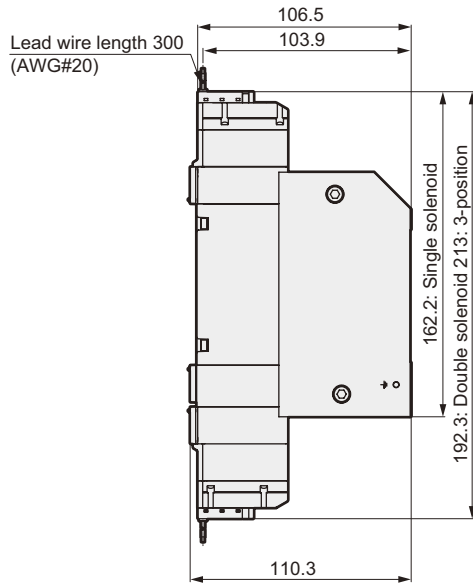

- External pilot (K)
Supply and exhaust block (Q)
E-connector type (E)

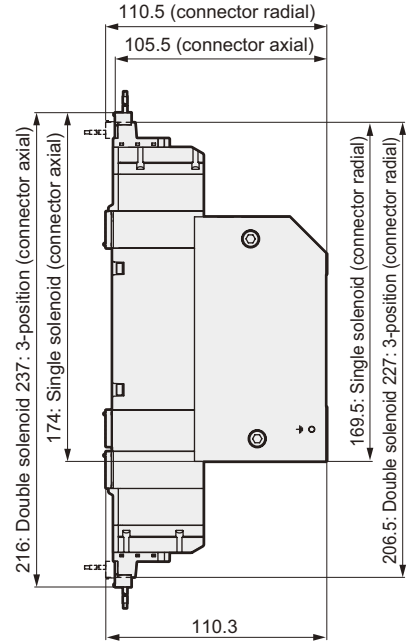

- External pilot (K)
Supply and exhaust block (Q)
EJ-connector type (E**J)

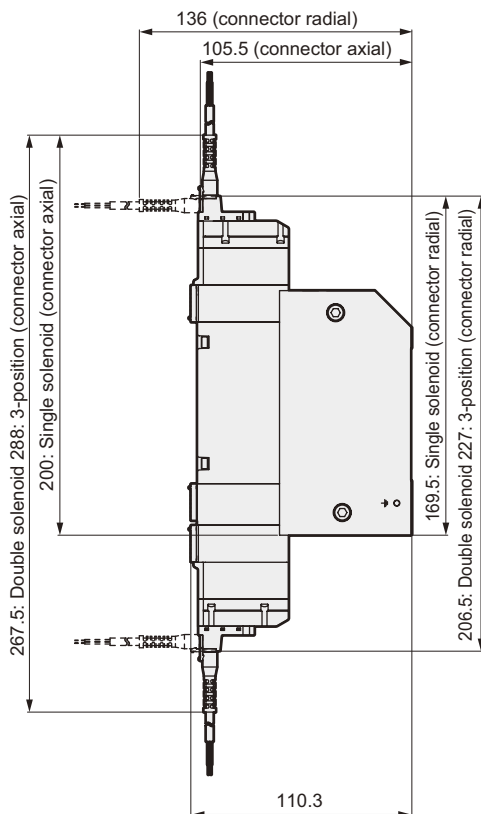

- External pilot (K)
Supply and exhaust block (Q)
DIN terminal box type (B)

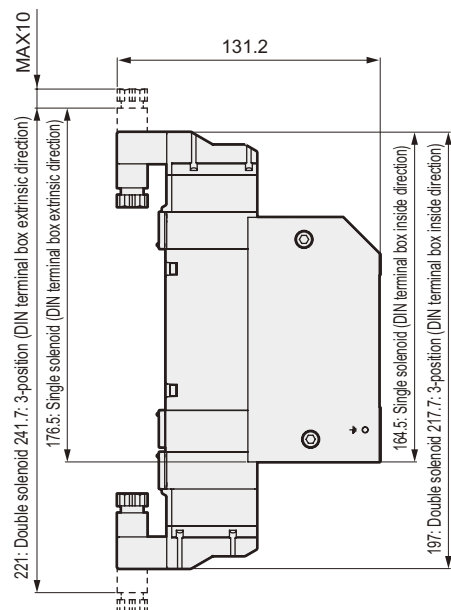

M4GA4/M4GB4 Series

Related products

Related products

● Air supply spacer

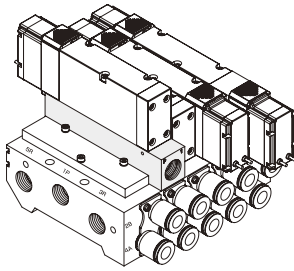

Specifications

Descriptions	4GA4	4GB4
Flow characteristics P → A/B	6.4	5.6
C [dm ³ /(s·bar)] Note 1	8.0	6.6
Weight	208	198

Note 1: This is a value when a single solenoid is installed.

Note 2: This is the value for installation on the manifold base port size Rc3/8.

Note 3: Effective sectional area S and sonic conductance C are converted as $S \approx 5.0 \times C$.

How to order discrete part

4GA4 - P - 10

▲ Port size

Valve model no.

Symbol	Descriptions	Valve model no.	
		4GA4	4GB4
▲ Port size			
10	Rc3/8	●	●
10G	G3/8	●	●
10N	NPT3/8	●	●

Accessories: 3 set screws, 2 O rings, 1 body gasket

⚠ Note on model no. selection

Note 1: Refer to manifold specifications in catalogs for the air supply spacer installation location and amount.

Note 2: Combination with the masking plate is not used.

Dimensions

● 4GA4

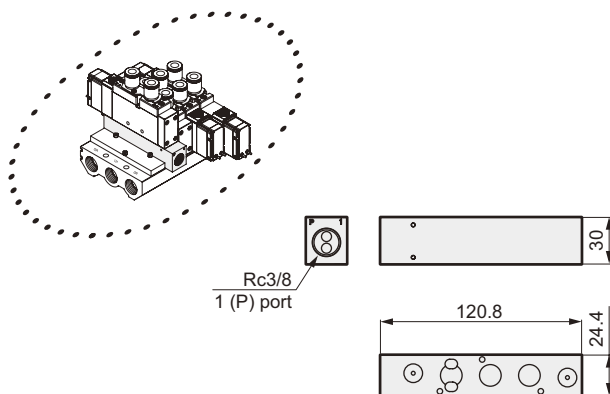

● 4GB4

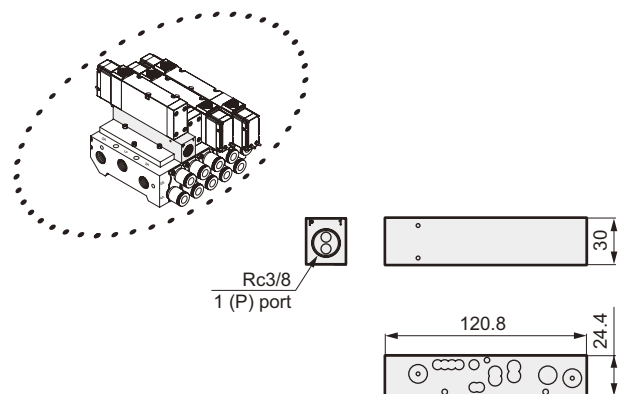

Dimensions when installed

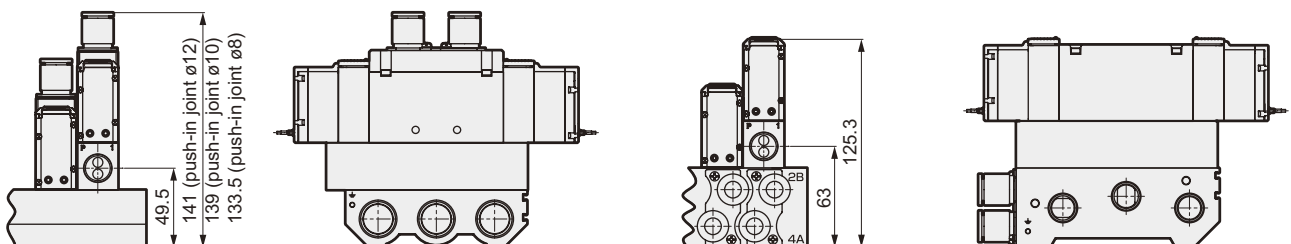

Related products

● Exhaust spacer

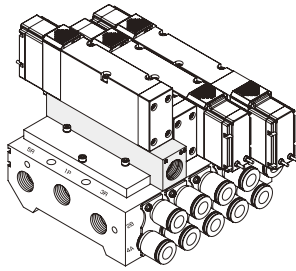

Specifications

Descriptions	4GA4	4GB4
Flow characteristics P → A/B	6.3	5.4 Note 2
C [dm ³ /(s·bar)] Note 1 A/B → R	6.9	5.7 Note 2
Weight g	206	197

Note 1: This is a value when a single solenoid is installed.

Note 2: This is the value for installation on the manifold base port size Rc3/8.

Note 3: Effective sectional area S and sonic conductance C are converted as $S \approx 5.0 \times C$.

How to order discrete part

4GA4 - R - 10

Ⓐ Port size

Valve model no.	
4GA4	4GB4

Symbol	Descriptions	4GA4	4GB4
Ⓐ Port size			
10	Rc3/8	●	●
10G	G3/8	●	●
10N	NPT3/8	●	●

Accessories: 3 set screws, 2 O rings, 1 body gasket

⚠ Note on model no. selection

Note 1: Refer to manifold specifications in catalogs for the air supply spacer installation location and amount.

Note 2: Combination with the masking plate is not used.

Note 3: When installing an exhaust spacer on the type A or B manifold (P port Rc3/8 specifications), use a push-in joint.

Dimensions

● 4GA4

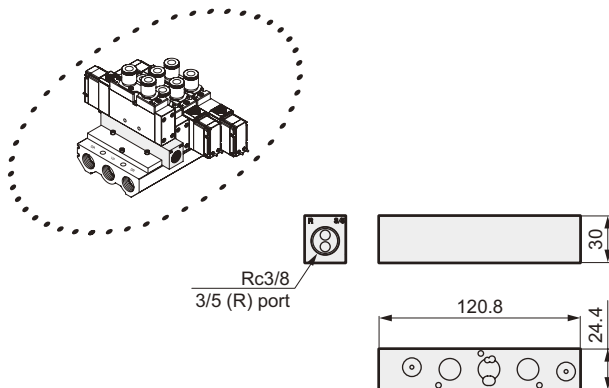

● 4GB4

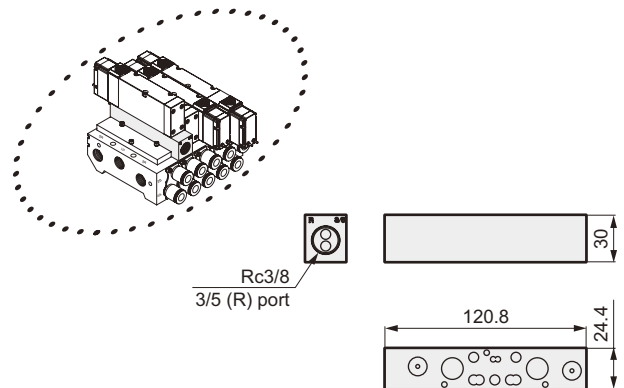

Dimensions when installed

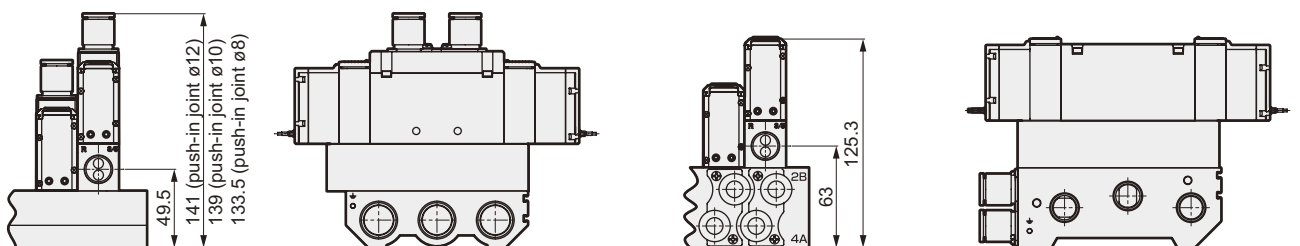

M4GA4/M4GB4 Series

Related products

Related products

● Silencer

● SLW-6A, 10A, 10L, 15A

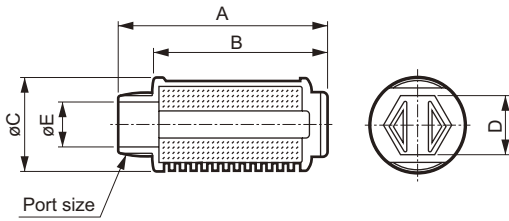

Symbol	Damping effect	Effective	A	B	C	D	E	Port size
Model no.	dB (A)	sectional area						
		mm ²						
SLW-6A	30 and over	10	34.5	28	16.5	10	7	R1/8
SLW-8A	30 and over	20	44.5	36	20	13	8.5	R1/4
SLW-8L	30 and over	30	57.4	48.5	25.5	17	8.5	R1/4
SLW-10A	30 and over	30	58.5	48.5	25.5	17	12	R3/8
SLW-10L	30 and over	60	68.2	58.4	28	19	12	R3/8
SLW-15A	30 and over	75	71.4	58.4	28	19	15	R1/2

● SLW-6S

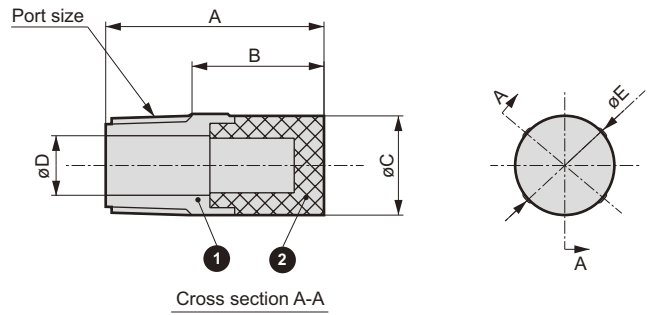

Model no.	Port size	A	B	C	D	E
SLW-6S	R1/8	22	13.3	10.5	6	10.5

● Plug types

Part name	Model no.	Appearance
Blanking plug	GWP-8B GWP-10B GWP-12B	
Screw plug	4G4-10P 4G4-15P	 Plug with hexagon head hole

Related products

● Masking plate kit

- For 4GA4
4GA4-MP
- For 4GB4
4GB4-MP

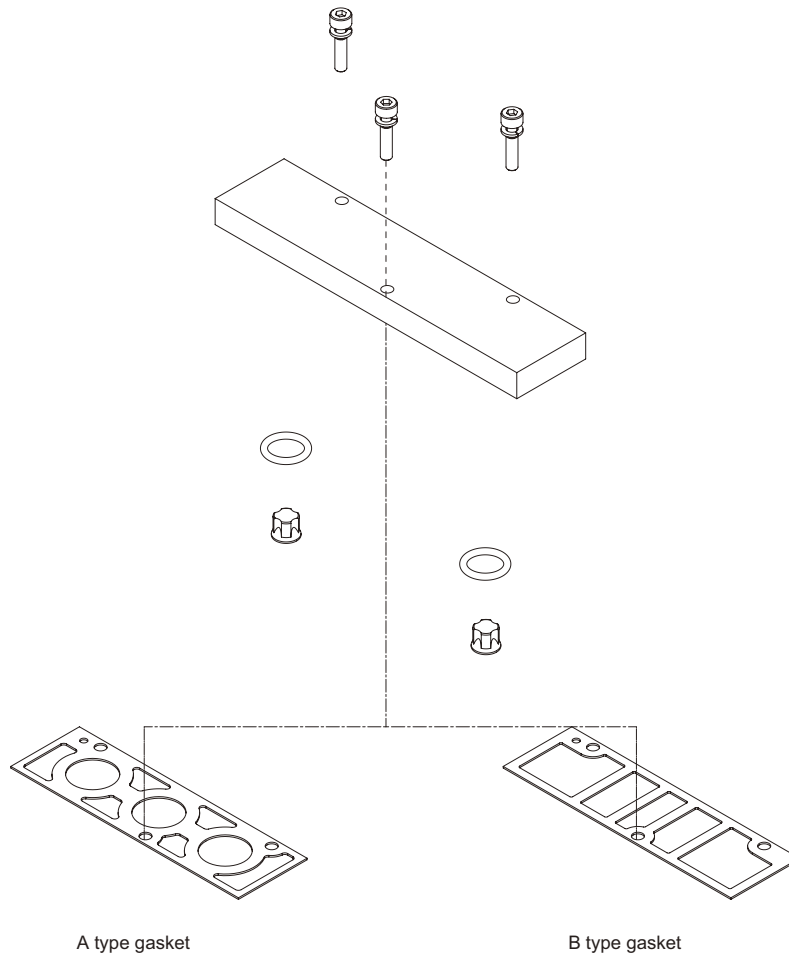

*Kit contents: Masking plate, gasket (select from type A or B), 3 set screws,
2 O-rings, 2 rapid exhaust valves

M4GA4/M4GB4 Series

Manifold specifications

Preparing metal base M4G4 series manifold specifications

● Manifold model no. (example)

M 4 G^A_B 4 8 0- CX - - 9 - 3
 Solenoid valve type Solenoid position Port size Electric connection Station number Voltage

Cautions on mix joint CX

Port joint A/B is selected as needed by indicating "CX" in the port size field.

Available cartridge joint

4G4 C8, C10, C12

When using female thread specifications, indicate the required number of plugs in the "Screw plug" field at the end.

The female threads and cartridge joint cannot be used together in one manifold set.

Solenoid valve model no.	Joint CX		Installation position																								Usage	
	A	B	1	2	3	4	5	6	7	8	9	10	11	12	13	14	15	16	17	18	19	20	21	22	23	24		
4G B 4 1 9- C8			○	○																								2
4G B 4 2 9- C8					○	○																						2
4G B 4 3 9- C8							○	○																				2
4G B 4 5 9- CX	C8	C10							○	○																		2
4G 4 9-																												
Masking plate 4G B 4-MP											○																	1
Mounting rail L ₂ =	Accessories		Blanking plug												Silencer													
			GWP8-B				GWP10-B				GWP12-B				SLW-15A													

Indicate "CX" when changing the joint combination.

References circuit diagram

The circuit diagram for the above manifold (example) is shown below.

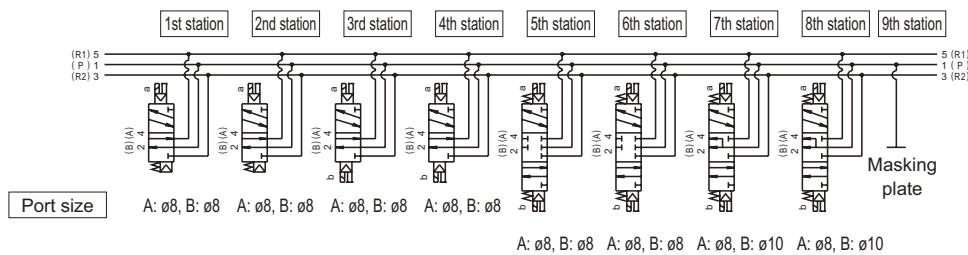

* Manifold station numbers are set in order from the left facing the piping port.

Individual wiring

M4G^A_B4, manifold specifications

Issue / /

Contact Quantity Set Request date
 Slip No. _____ Order No. _____

Your company name _____

Contact _____

Manifold model no. _____ Purchase order No. _____

M **G^A_B4** **0-** - - -
 Solenoid valve type Solenoid position Port size Electric connection Other options Mount type Station number Voltage

Solenoid valve model no.	Joint CX		Valve installation position																								Usage		
	A	B	1	2	3	4	5	6	7	8	9	10	11	12	13	14	15	16	17	18	19	20	21	22	23	24			
4G <input type="text"/> 4 <input type="text"/> 9- <input type="text"/>																													
4G <input type="text"/> 4 <input type="text"/> 9- <input type="text"/>																													
4G <input type="text"/> 4 <input type="text"/> 9- <input type="text"/>																													
4G <input type="text"/> 4 <input type="text"/> 9- <input type="text"/>																													
4G <input type="text"/> 4 <input type="text"/> 9- <input type="text"/>																													
Masking plate 4G <input type="text"/> 4-MP																													
Air supply spacer 4G <input type="text"/> 4-P- <input type="text"/>																													
Exhaust spacer 4G <input type="text"/> 4-R- <input type="text"/>																													
Mounting rail L ₂ = <input type="text"/>			Blanking plug						Silencer																				
Accessories			GWP8-B	GWP10-B	GWP12-B	SLW-10A	SLW-10L	SLW-15A																					

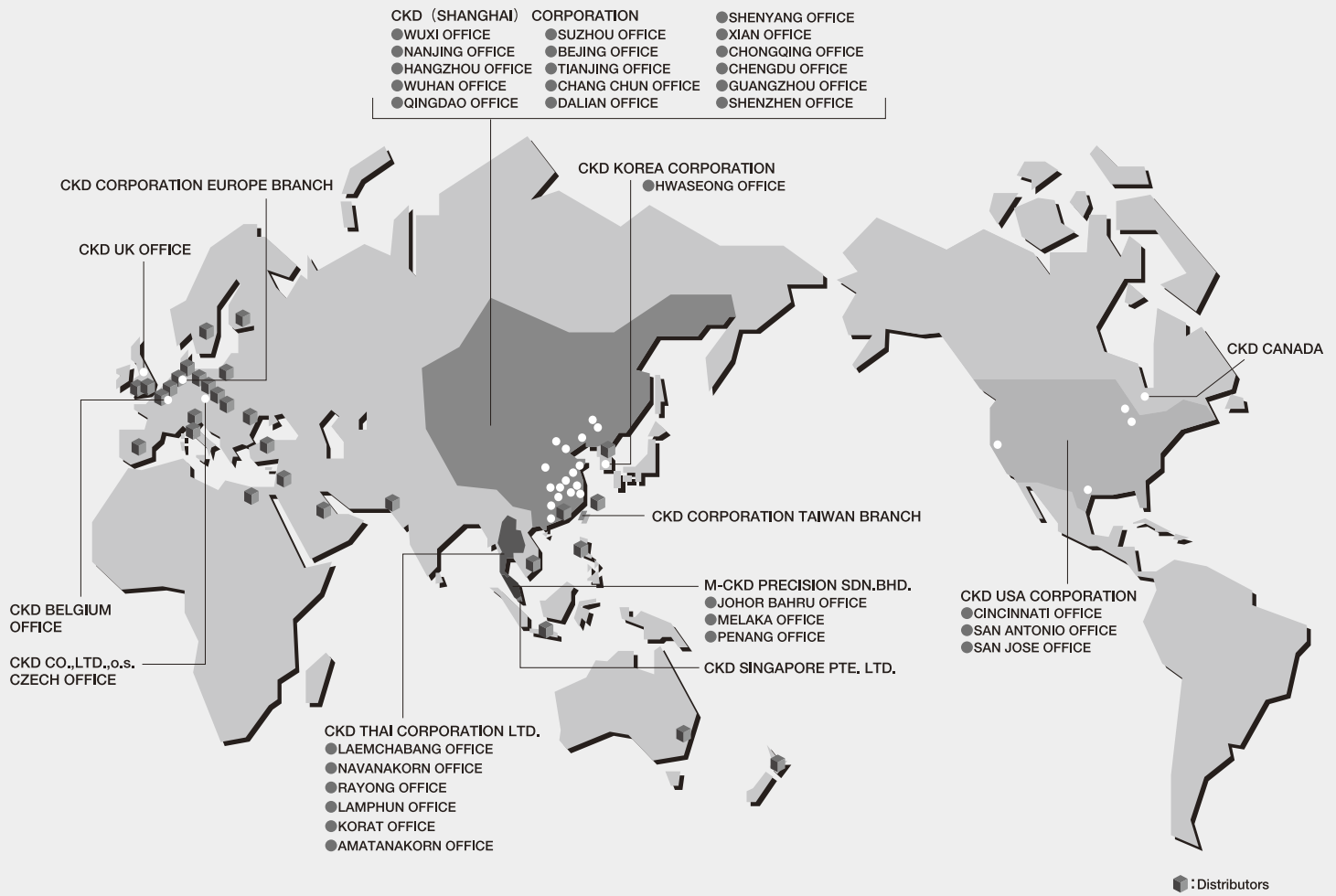

CKD Corporation

- OVERSEAS DPT. SALES DIV. 2-250 Uji Komaki, Aichi 485-8551, Japan
- PHONE +81-(0)568-74-1338 FAX +81-(0)568-77-3461

U.S.A

CKD USA CORPORATION

● HEADQUARTERS

4080 Winnetka Avenue, Rolling Meadows, IL 60008 USA
PHONE +1-847-368-0539 FAX +1-847-788-0575

EUROPE

CKD EUROPE BRANCH

De Fruittuinen 28 Hoofddorp 2132NZ The Netherlands
PHONE +31-(0)23-5541490 FAX +31-(0)23-5541491

Malaysia

M-CKD PRECISION SDN.BHD.

● HEADQUARTERS

Lot No.6,Jalan Modal 23/2, Seksyen 23, Kawasan, MIEL,
Fasa 8, 40300 Shah Alam,Selangor Darul Ehsan, Malaysia
PHONE +60-(0)3-5541-1468 FAX +60-(0)3-5541-1533

Thailand

CKD THAI CORPORATION LTD.

● SALES HEADQUARTERS-BANGKOK OFFICE

Suwan Tower, 14/1 Soi Saladaeng 1, North Sathorn Rd.,
Bangrak, Bangkok 10500 Thailand
PHONE +66-(0)2-267-6300 FAX +66-(0)2-267-6305

Singapore

CKD SINGAPORE PTE LTD.

705 Sims Drive #03-01/02, Shun Li Industrial Complex,
387384 Singapore
PHONE +65-6744-2623 FAX +65-6744-2486

Taiwan

CKD CORPORATION TAIWAN BRANCH

Rm.1405, 14F, No.96, Sec.2, Chung Shan N.Rd., Taipei,
Taiwan, R.O.C.
PHONE +886-(0)2-2523-0374 FAX +886-(0)2-2523-5081

Website <http://www.ckd.co.jp/>

China

CKD (SHANGHAI) CORPORATION

● SALES HEADQUARTERS / SHANGHAI OFFICE

Room 1903, 333 Jiujiang Road, Shanghai, 200001,
China
PHONE +86-(0)21-63602277 FAX +86-(0)21-63511661

Korea

CKD KOREA CORPORATION

Room No.1105, 11th FL, The Korea Teachers
Pention B/L, 27-2, Yoido-Dong, Youngdeungpo-Gu,
Seoul, 150-742, Korea
PHONE +82-(0)2-783-5201~5203 FAX +82-(0)2-783-5204

The goods and their replicas, or the technology and software in this catalog are subject to complementary export regulations by Foreign Exchange and Foreign Trade Law of Japan.

If the goods and their replicas, or the technology and software in this catalog are to be exported, laws require the exporter to make sure they will never be used for the development or the manufacture of weapons for mass destruction.